

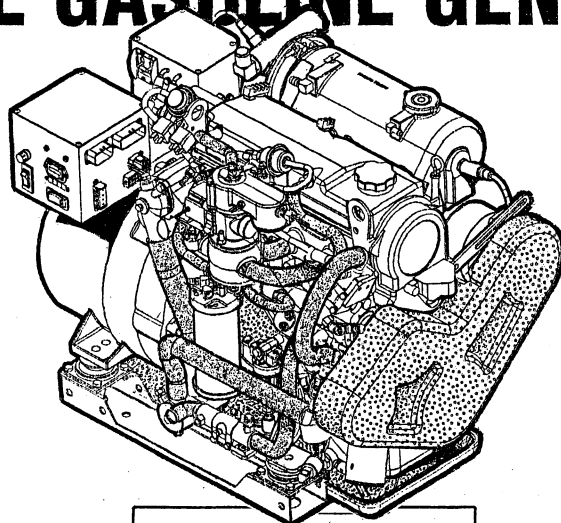

OPERATORS MANUAL

8.0KW - 60Hz SBEG / 6.4KW - 50 Hz SBEG
10.0KW - 60Hz SBEG / 8.0KW - 50 Hz SBEG
12.5KW - 60Hz SBEG / 10.0KW - 50 Hz SBEG
14.0KW - 60Hz SBEG / 11.6KW - 50 Hz SBEG
MARINE GASOLINE GENERATORS



PUBLICATION NO. 49735
REVISION 6
OCTOBER 2012



Low Carbon Monoxide Emissions

**CALIFORNIA PROPOSITION 65
WARNING**

Exhaust gas from diesel and gasoline engines (and some of its constituents) are known to the State of California to cause cancer, birth defects, and other reproductive harm.

 **WARNING:**

Exhaust gasses contain Carbon Monoxide, an odorless and colorless gas. Carbon Monoxide is poisonous and can cause unconsciousness and death. Symptoms of Carbon Monoxide exposure can include:

- *Dizziness*
- *Nausea*
- *Headache*
- *Weakness and Sleepiness*
- *Throbbing in Temples*
- *Muscular Twitching*
- *Vomiting*
- *Inability to Think Coherently*

IF YOU OR ANYONE ELSE EXPERIENCE ANY OF THESE SYMPTOMS, GET OUT INTO THE FRESH AIR IMMEDIATELY. If symptoms persist, seek medical attention. Shut down the unit and do not restart until it has been inspected and repaired.

A WARNING DECAL is provided by WESTERBEKE and should be fixed to a bulkhead near your engine or generator.

WESTERBEKE also recommends installing CARBON MONOXIDE DETECTORS in the living/sleeping quarters of your vessel. They are inexpensive and easily obtainable at your local marine store.



WESTERBEKE CORPORATION • MYLES STANDISH INDUSTRIAL PARK
150 JOHN HANCOCK ROAD, TAUNTON, MA 02780-7319 U.S.A.
TEL: (508) 823-7677 • FAX: (508) 884-9688 • Website: www.westerbeke.com

Gasoline with an ETHANOL content higher than 10% (E10) is **not allowed and may void warranty.**



WESTERBEKE™
Engines & Generators

SAFETY INSTRUCTIONS

INTRODUCTION

Read this safety manual carefully. Most accidents are caused by failure to follow fundamental rules and precautions. Know when dangerous conditions exist and take the necessary precautions to protect yourself, your personnel, and your machinery.

The following safety instructions are in compliance with the American Boat and Yacht Council (ABYC) standards.

PREVENT ELECTRIC SHOCK

⚠ WARNING: Do not touch AC electrical connections while engine is running, or when connected to shore power. Lethal voltage is present at these connections!

- Do not operate this machinery without electrical enclosures and covers in place.
- Shut off electrical power before accessing electrical equipment.
- Use insulated mats whenever working on electrical equipment.
- Make sure your clothing and skin are dry, not damp (particularly shoes) when handling electrical equipment.
- Remove wristwatch and all jewelry when working on electrical equipment.
- Do not connect utility shore power to vessels AC circuits, except through a ship-to-shore double throw transfer switch. Damage to vessels AC generator may result if this procedure is not followed.
- Electrical shock results from handling a charged capacitor. Discharge capacitor by shorting terminals together.

PREVENT BURNS — HOT ENGINE

⚠ WARNING: Do not touch hot engine parts or exhaust system components. A running engine gets very hot!

- Always check the engine coolant level at the coolant recovery tank.

⚠ WARNING: Steam can cause injury or death!

- In case of an engine overheat, allow the engine to cool before touching the engine or checking the coolant.

PREVENT BURNS — FIRE

⚠ WARNING: Fire can cause injury or death!

- Prevent flash fires. Do not smoke or permit flames or sparks to occur near the carburetor, fuel line, filter, fuel pump, or other potential sources of spilled fuel or fuel vapors. Use a suitable container to catch all fuel when removing the fuel line, carburetor, or fuel filters.
- Do not operate with a Coast Guard Approved flame arrester removed. Backfire can cause severe injury or death.
- Do not operate with the air cleaner/silencer removed. Backfire can cause severe injury or death.
- Do not smoke or permit flames or sparks to occur near the fuel system. Keep the compartment and the engine/generator clean and free of debris to minimize the chances of fire. Wipe up all spilled fuel and engine oil.
- Be aware — diesel fuel will burn.

PREVENT BURNS — EXPLOSION

⚠ WARNING: Explosions from fuel vapors can cause injury or death!

- Follow re-fueling safety instructions. Keep the vessels hatches closed when fueling. Open and ventilate cabin after fueling. Check below for fumes/vapor before running the blower. Run the blower for four minutes before starting your engine.
- All fuel vapors are highly explosive. Use extreme care when handling and storing fuels. Store fuel in a well-ventilated area away from spark-producing equipment and out of the reach of children.
- Do not fill the fuel tank(s) while the engine is running.
- Shut off the fuel service valve at the engine when servicing the fuel system. Take care in catching any fuel that might spill. DO NOT allow any smoking, open flames, or other sources of fire near the fuel system or engine when servicing. Ensure proper ventilation exists when servicing the fuel system.
- Do not alter or modify the fuel system.
- Be sure all fuel supplies have a positive shutoff valve.
- Be certain fuel line fittings are adequately tightened and free of leaks.
- Make sure a fire extinguisher is installed nearby and is properly maintained. Be familiar with its proper use. Extinguishers rated ABC by the NFPA are appropriate for all applications encountered in this environment.

SAFETY INSTRUCTIONS

ACCIDENTAL STARTING

⚠ WARNING: Accidental starting can cause injury or death!

- Disconnect the battery cables before servicing the engine/generator. Remove the negative lead first and reconnect it last.
- Make certain all personnel are clear of the engine before starting.
- Make certain all covers, guards, and hatches are re-installed before starting the engine.

BATTERY EXPLOSION

⚠ WARNING: Battery explosion can cause injury or death!

- Do not smoke or allow an open flame near the battery being serviced. Lead acid batteries emit hydrogen, a highly explosive gas, which can be ignited by electrical arcing or by lit tobacco products. Shut off all electrical equipment in the vicinity to prevent electrical arcing during servicing.
- Never connect the negative (-) battery cable to the positive (+) connection terminal of the starter solenoid. Do not test the battery condition by shorting the terminals together. Sparks could ignite battery gases or fuel vapors. Ventilate any compartment containing batteries to prevent accumulation of explosive gases. To avoid sparks, do not disturb the battery charger connections while the battery is being charged.
- Avoid contacting the terminals with tools, etc., to prevent burns or sparks that could cause an explosion. Remove wristwatch, rings, and any other jewelry before handling the battery.
- Always turn the battery charger off before disconnecting the battery connections. Remove the negative lead first and reconnect it last when disconnecting the battery.

BATTERY ACID

⚠ WARNING: Sulfuric acid in batteries can cause severe injury or death!

- When servicing the battery or checking the electrolyte level, wear rubber gloves, a rubber apron, and eye protection. Batteries contain sulfuric acid which is destructive. If it comes in contact with your skin, wash it off at once with water. Acid may splash on the skin or into the eyes inadvertently when removing electrolyte caps.

TOXIC EXHAUST GASES

⚠ WARNING: Carbon monoxide (CO) is a deadly gas!

- Ensure that the exhaust system is adequate to expel gases discharged from the engine. Check the exhaust system regularly for leaks and make sure the exhaust manifolds/water-injected elbow is securely attached.
- Be sure the unit and its surroundings are well ventilated. Run blowers when running the generator set or engine.
- Do not run the generator set or engine unless the boat is equipped with a functioning marine carbon monoxide detector that complies with ABYCA-24. Consult your boat builder or dealer for installation of approved detectors.
- For additional information refer to ABYC T-22 (educational information on Carbon Monoxide).

⚠ WARNING: Carbon monoxide (CO) is an invisible odorless gas. Inhalation produces flu-like symptoms, nausea or death!

- Do not use copper tubing in diesel exhaust systems. Diesel fumes can rapidly destroy copper tubing in exhaust systems. Exhaust sulfur causes rapid deterioration of copper tubing resulting in exhaust/water leakage.
- Do not install exhaust outlet where exhaust can be drawn through portholes, vents, or air conditioners. If the engine exhaust discharge outlet is near the waterline, water could enter the exhaust discharge outlet and close or restrict the flow of exhaust. Avoid overloading the craft.
- Although diesel engine exhaust gases are not as toxic as exhaust fumes from gasoline engines, carbon monoxide gas is present in diesel exhaust fumes. Some of the symptoms or signs of carbon monoxide inhalation or poisoning are:

Vomiting	Inability to think coherently
Dizziness	Throbbing in temples
Headache	Muscular twitching
Nausea	Weakness and sleepiness

AVOID MOVING PARTS

⚠ WARNING: Rotating parts can cause injury or death!

- Do not service the engine while it is running. If a situation arises in which it is absolutely necessary to make operating adjustments, use extreme care to avoid touching moving parts and hot exhaust system components.

SAFETY INSTRUCTIONS

- Do not wear loose clothing or jewelry when servicing equipment; tie back long hair and avoid wearing loose jackets, shirts, sleeves, rings, necklaces or bracelets that could be caught in moving parts.
- Make sure all attaching hardware is properly tightened. Keep protective shields and guards in their respective places at all times.
- Do not check fluid levels or the drive belts tension while the engine is operating.
- Stay clear of the drive shaft and the transmission coupling when the engine is running; hair and clothing can easily be caught in these rotating parts.

HAZARDOUS NOISE

 **WARNING: High noise levels can cause hearing loss!**

- Never operate an engine without its muffler installed.
- Do not run an engine with the air intake (silencer) removed.
- Do not run engines for long periods with their enclosures open.

 **WARNING: Do not work on machinery when you are mentally or physically incapacitated by fatigue!**

OPERATORS MANUAL

Many of the preceding safety tips and warnings are repeated in your Operators Manual along with other cautions and notes to highlight critical information. Read your manual carefully, maintain your equipment, and follow all safety procedures.

GASOLINE ENGINE AND GENERATOR INSTALLATIONS

Preparations to install an engine should begin with a thorough examination of the American Boat and Yacht Council's (ABYC) standards. These standards are a combination of sources including the USCG and the NFPA.

Sections of the ABYC standards of particular interest are:

- H-2 Ventilation
- P-1 Exhaust Systems
- P-4 Inboard Engines
- E-9 DC Electrical Systems

All installations must comply with the Federal Code of Regulations (FCR).

ABYC, NFPA AND USCG PUBLICATIONS FOR INSTALLING DIESEL ENGINES

Read the following ABYC, NFPA and USCG publications for safety codes and standards. Follow their recommendations when installing your engine.

ABYC (American Boat and Yacht Council)
"Safety Standards for Small Craft"

Order from:

ABYC
3069 Solomon's Island Rd.
Edgewater, MD 21037

NFPA (National Fire Protection Association)
"Fire Protection Standard for Motor Craft"

Order from:

NFPA
11 Tracy Drive
Avon Industrial Park
Avon, MA 02322

USCG (United States Coast Guard)
"USCG 33CFR183"

Order from:

U.S. Government Printing Office
Washington, D.C. 20404

INSTALLATION

When installing WESTERBEKE engines and generators it is important that strict attention be paid to the following information:

CODES AND REGULATIONS

Strict federal regulations, ABYC guidelines, and safety codes must be complied with when installing engines and generators in a marine environment.

SIPHON-BREAK

For installations where the exhaust manifold/water injected exhaust elbow is close to or will be below the vessel's waterline, provisions must be made to install a siphon-break in the raw water supply hose to the exhaust elbow. This hose must be looped a minimum of 20" above the vessel's waterline. *Failure to use a siphon-break when the exhaust manifold/water injected exhaust elbow is near or below the loaded water line of the vessel will result in raw water damage to the engine and possible flooding of the vessel.*

If you have any doubt about the position of the water-injected exhaust elbow relative to the vessel's waterline under the vessel's various operating conditions, *install a siphon-break.*

NOTE: *A siphon-break requires periodic inspection and cleaning to ensure proper operation. Failure to properly maintain a siphon-break can result in catastrophic engine damage. Consult the siphon-break manufacturer for proper maintenance.*

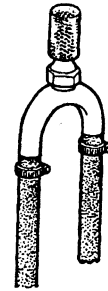

AVAILABLE FROM
YOUR WESTERBEKE
DEALER

SIPHON-BREAK WITH STAINLESS
LOOP FOR 1" HOSE
PART NO. 044010

EXHAUST SYSTEM

The exhaust system's hose MUST be certified for marine use. Corrugated Marine Exhaust Hose is recommended. The use of this type of hose allows for extreme bends and turns without the need of additional fitting and clamps to accomplish these bends and turns. In this regard, a single length of corrugated exhaust hose can be used. The system MUST be designed to prevent the entry of water into the exhaust system under any sea conditions and at any angle of vessels heel.

A detailed Marine Installation Manual covering gasoline and diesel engines and generators is supplied with every unit sold. This manual is also available in pdf format on our website to download

Website: www.westerbeke.com

TABLE OF CONTENTS

Parts Identification	2	Engine Troubleshooting Guide	27
Introduction	3	Electrical Troubleshooting Guide	29
Warranty Procedure	3	System Monitoring Software	30
Serial Number Location	4	Data Logging (Troubleshooting)	31
Fuel, Engine Oil and Engine Coolant	5	DC Electrical System	35
Preparations for Initial Start-Up	6	Battery Care	36
Starting/Stopping Procedure	7	Wiring Schematic #49167	37
Remote Panel	8	Remote Panel Wiring	38
Break-In Procedure/Daily Operation	8	Starter Motor	39
Safety Shutdown Sensors	9	Generator Information	41
Maintenance Schedule	10	AC Voltage Regulator (Current Models)	42
Measuring Exhaust Back Pressure	11	Exciting the Generator	42
Fuel System	12	AC Voltage Connections	43
Bleeding the Fuel System	13	BE Generators/Early Models	44
Electronic Fuel Injection (EFI)	14	AC Voltage Regulator (Early Models)	46
Cooling System	15	AC Voltage Connections	47
Changing Coolant	15	Exciting the Generator	47
Thermostat	16	BE Generator (Troubleshooting)	48
Raw Water Pump	17	Engine/Generator Specifications	49
Raw Water Intake Strainer	17	Shore Power Transfer Switch	50
Engine Lubrication Oil	18	Lay-Up and Recommissioning	51
Oil Filter	18	“CO” Data (Important)	53
Remote Oil Filter	19	Installing a New Catalyst	54
Throttle Body Assembly	20	Emissions Data	55
Engine Adjustments	21	Metric Conversions	56
Spark Plugs	21	Suggested Spare Parts	57
High Tension Cords	21		
Drive Belt Adjustment	21		
Fuel Pressure Test	21		
Engine Compression Test	22		
Ignition timing	22		
Valve Clearance	23		
Testing the Igniter	23		
Timing Belt Inspection and Replacement	24		

PARTS IDENTIFICATION

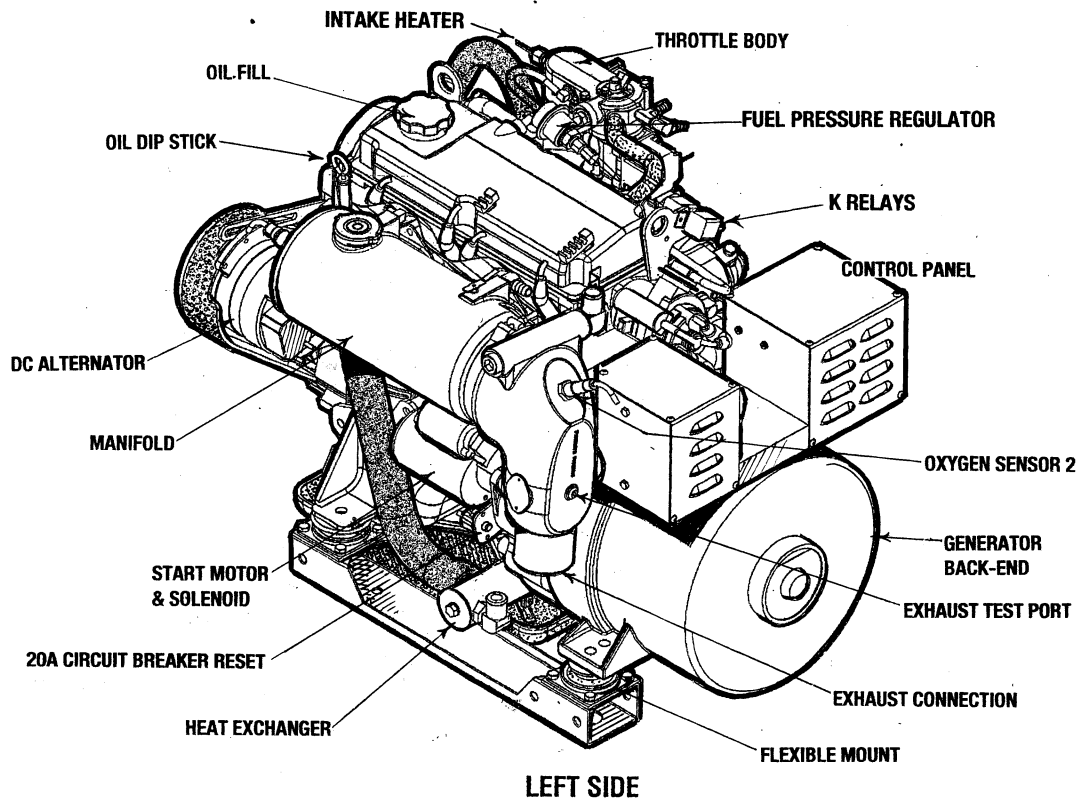
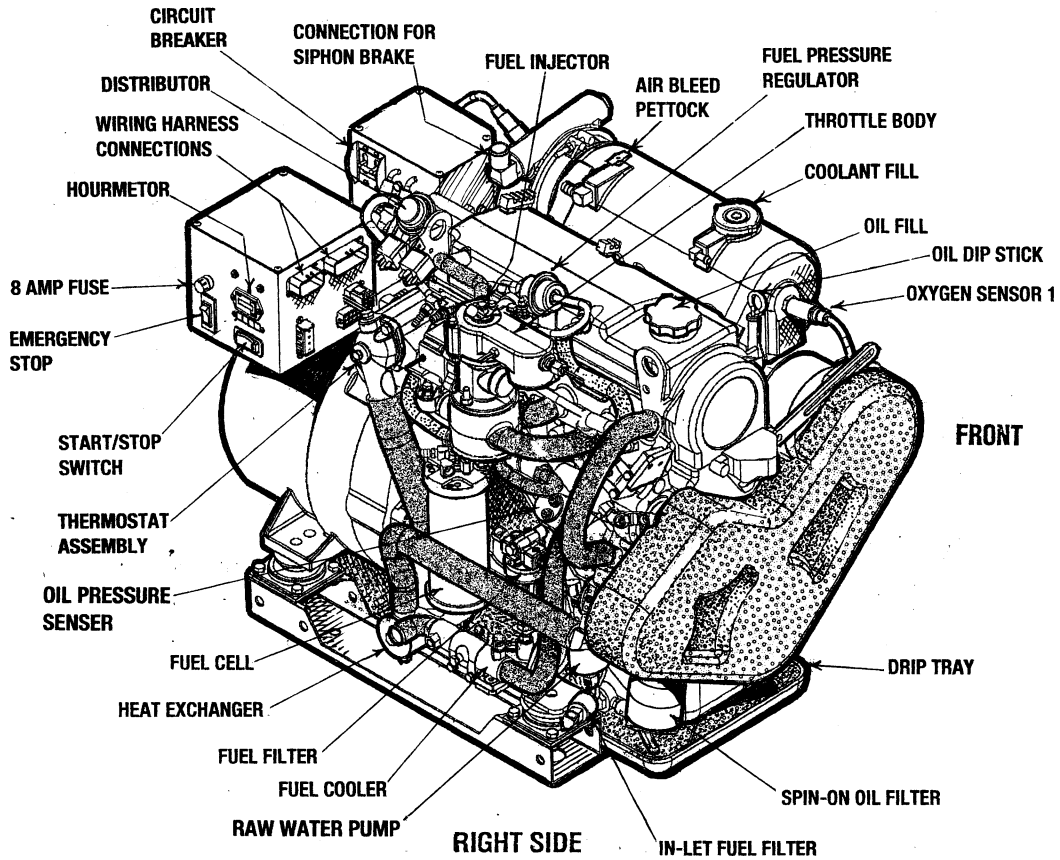

INTRODUCTION

This WESTERBEKE Generator is a product of WESTERBEKE'S long years of experience and advanced technology. We take great pride in the superior durability and dependable performance of our engines and generators. Thank you for selecting WESTERBEKE.

In order to get the full use and benefit from your generator, it is important that you operate and maintain it correctly. This manual is designed to help you do this. Please read this manual carefully and observe all the safety precautions throughout. Should your generator require servicing, contact your nearest WESTERBEKE dealer for assistance.

This is your Operators Manual. A Parts Catalog is also provided and a Technical Manual is available from your WESTERBEKE dealer. If you are planning to install this equipment yourself, contact your WESTERBEKE dealer for WESTERBEKE'S Installation Manual.

WARRANTY PROCEDURES

Your WESTERBEKE Warranty is included in a separate folder. If you have not received a customer identification card registering your warranty 60 days after submitting the warranty registration form, please contact the factory in writing with model information, including the unit's serial number and commission date



Customer Identification

WESTERBEKE OWNER
 MAIN STREET
 HOMETOWN, USA

Model _____ Ser. # _____
 Expires _____

PRODUCT SOFTWARE

Product software (tech data, parts lists, manuals, brochures and catalogs) provided from sources other than WESTERBEKE are not within WESTERBEKE'S CONTROL.

WESTERBEKE CANNOT BE RESPONSIBLE FOR THE CONTENT OF SUCH SOFTWARE, MAKES NO WARRANTIES OR REPRESENTATIONS WITH RESPECT THERETO, INCLUDING ACCURACY, TIMELINESS OR COMPLETENESS THEREOF AND WILL IN NO EVENT BE LIABLE FOR ANY TYPE OF DAMAGE OR INJURY INCURRED IN CONNECTION WITH OR ARISING OUT OF THE FURNISHING OR USE OF SUCH SOFTWARE.

WESTERBEKE customers should also keep in mind the time span between printings of WESTERBEKE product software and the unavoidable existence of earlier WESTERBEKE manuals. In summation, product software provided with WESTERBEKE products, whether from WESTERBEKE or other suppliers, must not and cannot be relied upon exclusively as the definitive authority on the respective product. It not only makes good sense but is imperative that appropriate representatives of WESTERBEKE or the supplier in question be consulted to determine the accuracy and currentness of the product software being consulted by the customer.

SERIAL NUMBER LOCATION

The generator serial number and model number are located on a decal on the generator housing. Take the time to enter the information on the blank decal provided. This will provide a quick reference when seeking technical information and/or ordering repair parts.

SPECIFICATION	50 HZ.	60 HZ.
MODEL		
RPM		
KW		
KVA		
VOLTS		
AMPS		
ENG. HP		
ENG. SER. NO.		
GEN. SER. NO.		
PF/PHASE	/	
WIRES		
RATING		
INSUL. CLASS		
TEMP. RISE		
BATTERY		
C.I.D.		

Fill in the information for your reference.



MODEL _____
SPEC _____
SER. NO. _____

Engine I.D. Plate

INTRODUCTION

ORDERING PARTS

Whenever replacement parts are needed, always provide the generator and engine model and serial numbers. In addition, include a complete part description and part number for each part needed (see the separately furnished Parts Catalog). Also insist upon WESTERBEKE packaged parts because *will fit* or generic parts are frequently not made to the same specifications as original equipment.

NOTES, CAUTIONS AND WARNINGS

As this manual takes you through the operating procedures, maintenance schedules, and troubleshooting of your generator, critical information will be highlighted by NOTES, CAUTIONS, and WARNINGS. An explanation follows:

NOTE: *An operating procedure essential to note.*

 **CAUTION:** *Procedures, which if not strictly observed, can result in the damage or destruction of the engine or generator.*

 **WARNING:** *Procedures, which if not properly followed, can result in personal injury or loss of life.*

NOTE: *A carbon monoxide warning decal has been provided by WESTERBEKE. Affix this decal in a visible location in the engine room.*

SPARES AND ACCESSORIES

Certain spare parts will be needed to support and maintain your WESTERBEKE generator or engine when cruising (see *SUGGESTED SPARE PARTS*). Often even simple items such as proper fuel and oil filter can be difficult to obtain along the way. WESTERBEKE will provide you with a suggested spares and accessories brochure to assist you in preparing an on-board inventory of the proper WESTERBEKE parts.

PROTECTING YOUR INVESTMENT

Care at the factory during assembly and thorough testing have resulted in a WESTERBEKE generator capable of many thousands of hours of dependable service. However the manufacturer cannot control how or where the generator is installed in the vessel or the manner in which the unit is operated and serviced in the field. This is up to the buyer/owner-operator.

NOTE: *Six important steps to ensure long generator life:*

- *Proper engine and generator installation and alignment.*
- *An efficient well-designed exhaust system that includes an anti-siphon break to prevent water from entering the engine.*
- *Changing the engine oil and oil filters every 100 operating hours.*
- *Proper maintenance of all engine and generator components according to the maintenance schedule in this manual.*
- *Use clean, filtered unleaded fuel.*
- *Winterize your engine according to the "Lay-up and Recommissioning" section in this manual.*

UNDERSTANDING THE GASOLINE GENERATOR

The gasoline engine driving an AC generator is in many ways similar to a gasoline automobile engine. The cylinders are verticle in-line, and the engine's cylinder head has an overhead camshaft which is chain-driven. The engine utilizes a solid-state distributor which is horizontally mounted and camshaft-driven. The engine incorporates a pressure type lubrication system, and a fresh water-cooled engine block which is thermostatically-controlled. To a large degree, the generator's engine requires the same preventive maintenance that is required of a gasoline automobile engine. The most important factors to the generator's longevity are proper ventilation, maintenance of the fuel system, ignition system, cooling system and the generator backend.

FUEL, ENGINE OIL AND ENGINE COOLANT

GASOLINE

CAUTION: Use unleaded 89 Octane gasoline or higher. Ethanol gasoline must not exceed must not exceed E10 (10%). Gasoline with higher percentages of Ethanol are not acceptable for use in these models and can void the warranty.

When fueling, follow U.S. Coast Guard procedures, closing hatches and companionways to prevent fumes from entering the boat and cabins. Be sure to ventilate after fueling.

Care Of The Fuel Supply

Use only clean fuel! The clearance of the components in your fuel injection pump is very critical; invisible dirt particles which might pass through the filter can damage these finely finished parts. It is important to buy clean fuel, and keep it clean. The best fuel can be rendered unsatisfactory by careless handling or improper storage facilities. To assure that the fuel going into the tank for your engine's daily use is clean and pure, the following practice is advisable:

Purchase a well-known brand of fuel.

Install and regularly service a good, Coast Guard approved metal bowl type filter/water separator between the fuel tank and the engine.

NOTE: It is recommended that the fuel system be bled during each oil and filter change interval to ensure no air has accumulated in the fuel system.

ENGINE OIL

Use a heavy duty engine oil with an API classification of SJ, SL, or SM. Change the engine oil and filter after an initial 50 hours of engine break-in operation. Then follow the oil and filter change intervals as specified in the **MAINTENANCE SCHEDULE** in this manual.

Westerbeke Corporation does not approve or disapprove the use of synthetic oils. If synthetic oils are used, engine break-in **MUST** be performed using conventional oil. Oil change intervals must be as listed in the **MAINTENANCE SCHEDULE** section in this manual and not to be extended if synthetic oils are used.

NOTE: The information above supersedes all previous statements regarding synthetic oil usage.

ENGINE COOLANT

WESTERBEKE recommends a mixture of 50% antifreeze and 50% distilled water. Distilled water is free from the chemicals that can corrode internal engine surfaces.

The antifreeze performs double duty. It allows the engine to run at proper temperatures by transferring heat away from the engine to the coolant. It also lubricates and protects the cooling circuit from rust and corrosion. Use a good quality antifreeze that contains supplemental cooling additives (SCAs) that keep the antifreeze chemically balanced, crucial to long term protection.

The water and antifreeze should be premixed before being poured into the cooling circuit.

NOTE: Use the new environmentally-friendly, long lasting, antifreeze that is now available.

A proper 50/50 mixture as recommended will protect the engine coolant to temperatures of -40°F

COOLANT RECOVERY TANK

A coolant recovery tank kit is supplied with each generator. The purpose of this recovery tank is to allow for engine coolant expansion and contraction during engine operation, without the loss of coolant and without introducing air into the cooling system.

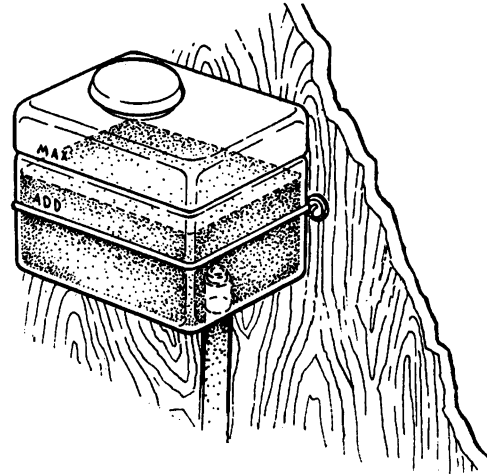

PREPARATIONS FOR INITIAL START-UP

PRESTART INSPECTION

Before starting your generator for the first time or after a prolonged layoff, check the following items:

- Check the engine oil level: add oil to maintain the level at the full mark on the dipstick.
- Check the fuel supply and examine the fuel filter/separator bowls for contaminants.
- Check the DC electrical system. Inspect wire connections and battery cable connections.
- Check the coolant level in both the plastic recovery tank and at the manifold.

NOTE: After the initial running of the generator, the air in the engine's cooling system will be purged to the coolant recovery tank. Open the air bleed petcock to ensure that the cooling system is purged of air. After shutdown and after the engine has cooled, the coolant from the recovery tank will be drawn into the engine's cooling system to replace the purged air.

Before subsequent operation of the generator, the engine's manifold should be topped off, and the coolant recovery tank may need to be filled to the MAX level.

- Visually examine the unit. Look for loose or missing parts, disconnected wires, unattached hoses, and check threaded connections. Search for any gasoline leaks.
- Check load leads for correct connections as specified in the wiring diagrams.
- Examine the air inlet and outlet for air flow obstructions.
- Be sure no other generator or utility power is connected to the load lines.
- Be sure that in power systems with a neutral line that the neutral is properly grounded (or ungrounded) as the system requires, and that generator neutral is properly connected to the load neutral. In single phase systems an incomplete or open neutral can supply the wrong line-to-neutral voltage on unbalanced loads.
- Make certain the raw water thru-hull is open.

CAUTION: When starting the generator, it is recommended that all AC loads, especially large motors, be switched OFF until the engine has come up to speed and, in cold climates, starts to warm up. This precaution will prevent damage caused by unanticipated operation of the AC machinery and will prevent a cold engine from stalling.

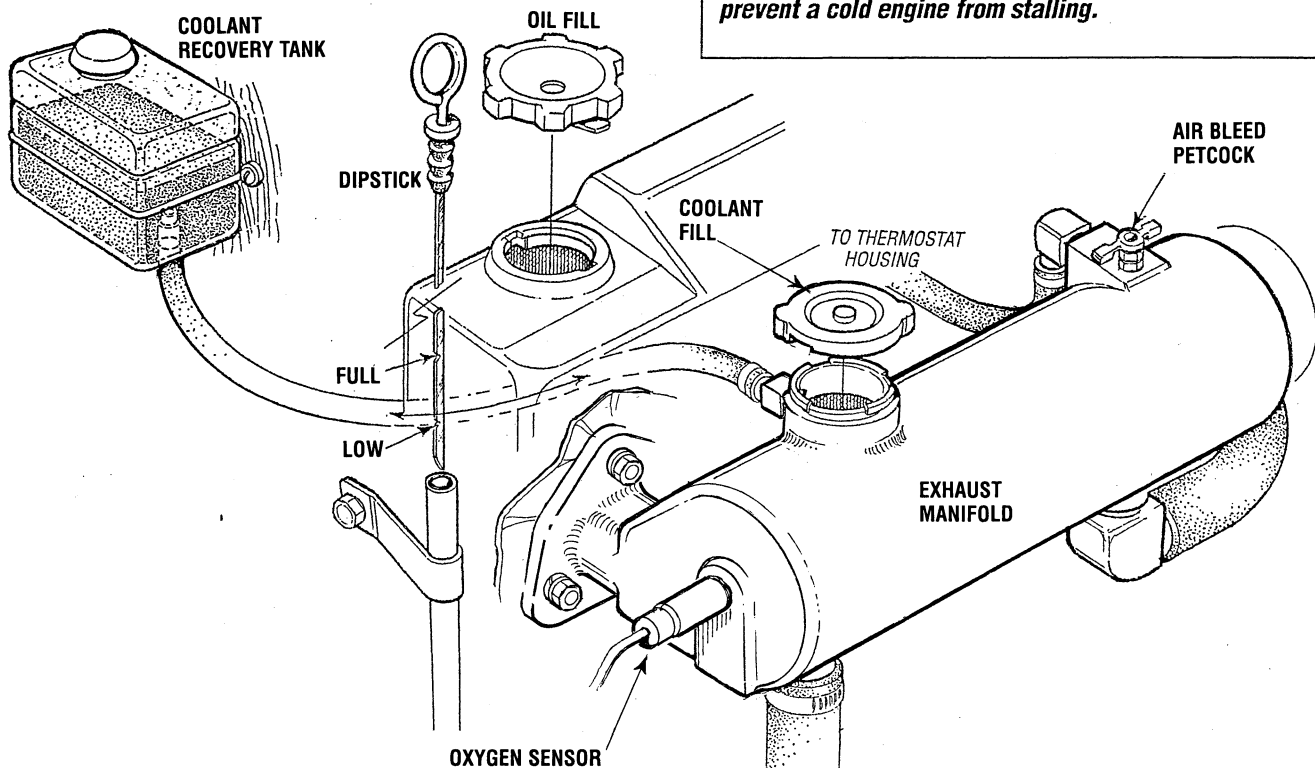

STARTING/STOPPING PROCEDURE

GENERATOR CONTROL PANEL

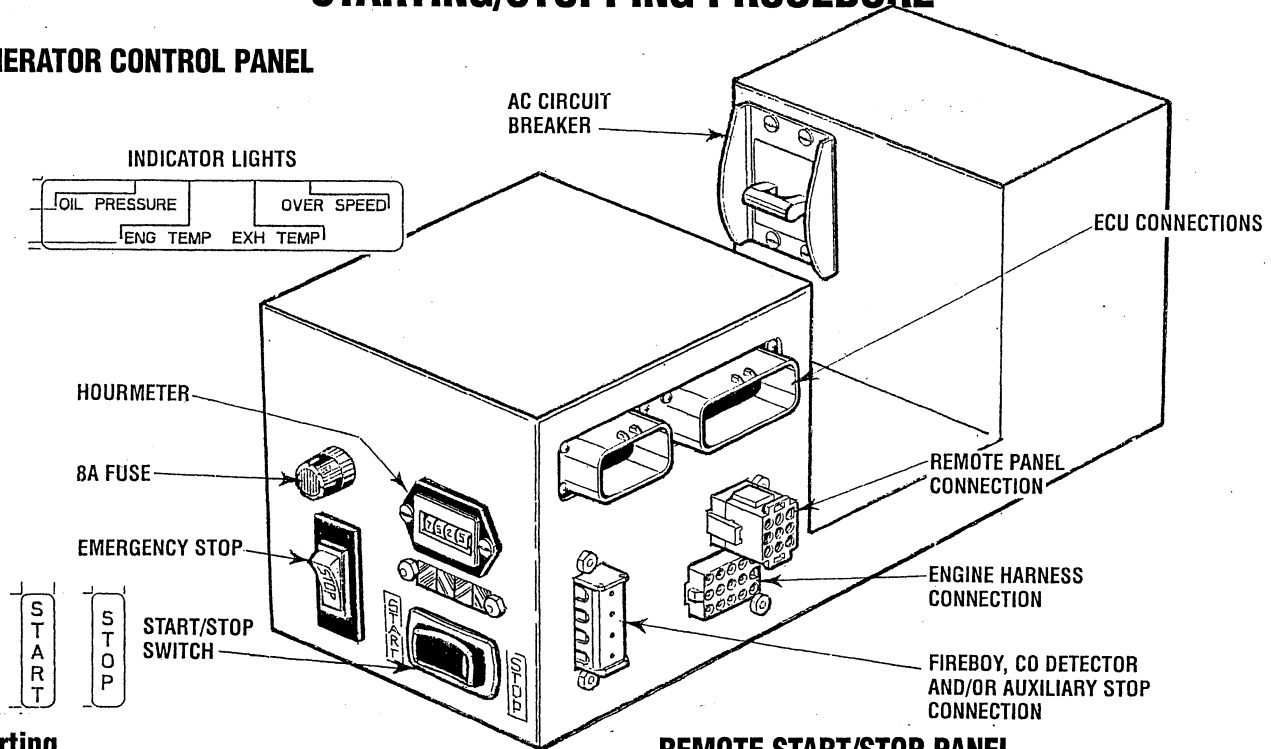

Starting

Simply press the **START** switch and the generator will start. A green light will glow indicating the generator is running.

Stopping

To stop-depress the **STOP** side of the start switch, the green light will go out and the generator is stopped.

Failure to Start

The start cycle will automatically terminate if the unit fails to start after 12-14 seconds of cranking. Wait 20 seconds, then repeat the start.

If the unit again fails to start, investigate the cause. Sometimes after servicing the fuel system or changing the fuel filter, air can accumulate in the fuel line or the throttle body and prevent starting.

The Schrader valves on the throttle body and the fuel cell are used to remove trapped air. This air is mixed with fuel and under high pressure. Follow the **BLEEDING THE FUEL SYSTEM** instructions in this manual.

REMOTE START/STOP PANEL

The components on the panel are:

1. A three position start/stop rocker switch.
2. A green LED run indicator light on the rocker switch.
3. A four position LED fault shut down display board.

The start/stop rocker switch functions the same as the start/stop rocker switch on the generator's control panel as previously explained.

The start/stop rocker switch indicator light on the rocker switch will illuminate when the start circuit is energized. It will go dim as the engine cranks and will brighten as the engine starts to indicate the generator is running.

The LED fault shut down display board has four separate LED lights to display to the operator the cause of the generators automatic shut down. The four LED displays are: low oil pressure, high engine operating temperature, high exhaust temperature and engine over-speed/under-speed (flashes).

Should the generator shut down from one of these faults, the fault LED will remain illuminated. To reset the LED, the stop switch must be momentarily depressed.

This remote panel is a plug-in accessory and is available with a 15' to 100' wiring harness.

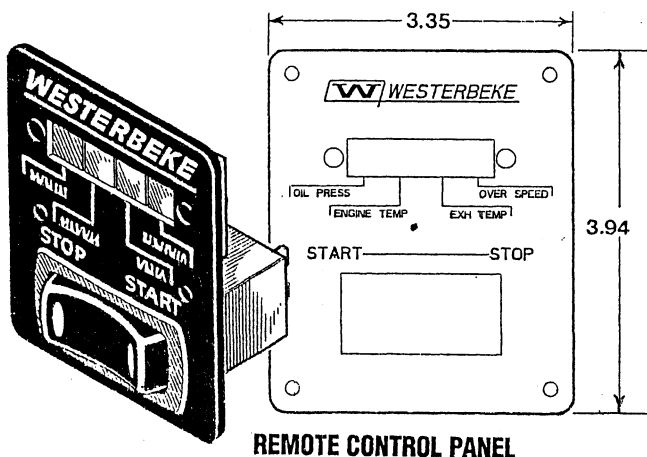

REMOTE CONTROL PANEL

CAUTION: Repeated crank cycles without a start can result in the engine's exhaust system filling with raw water. This raw water can enter the engine's cylinders by way of the exhaust manifold once the system fills. If after three crank cycles the unit does not start. Drain the system's muffler and investigate and correct the cause of no start. Engine damage the result of raw water entry is not a warrantable issue. The operator should keep this in mind.

STARTING/STOPPING PROCEDURE

GENERATOR CONTROL PANEL

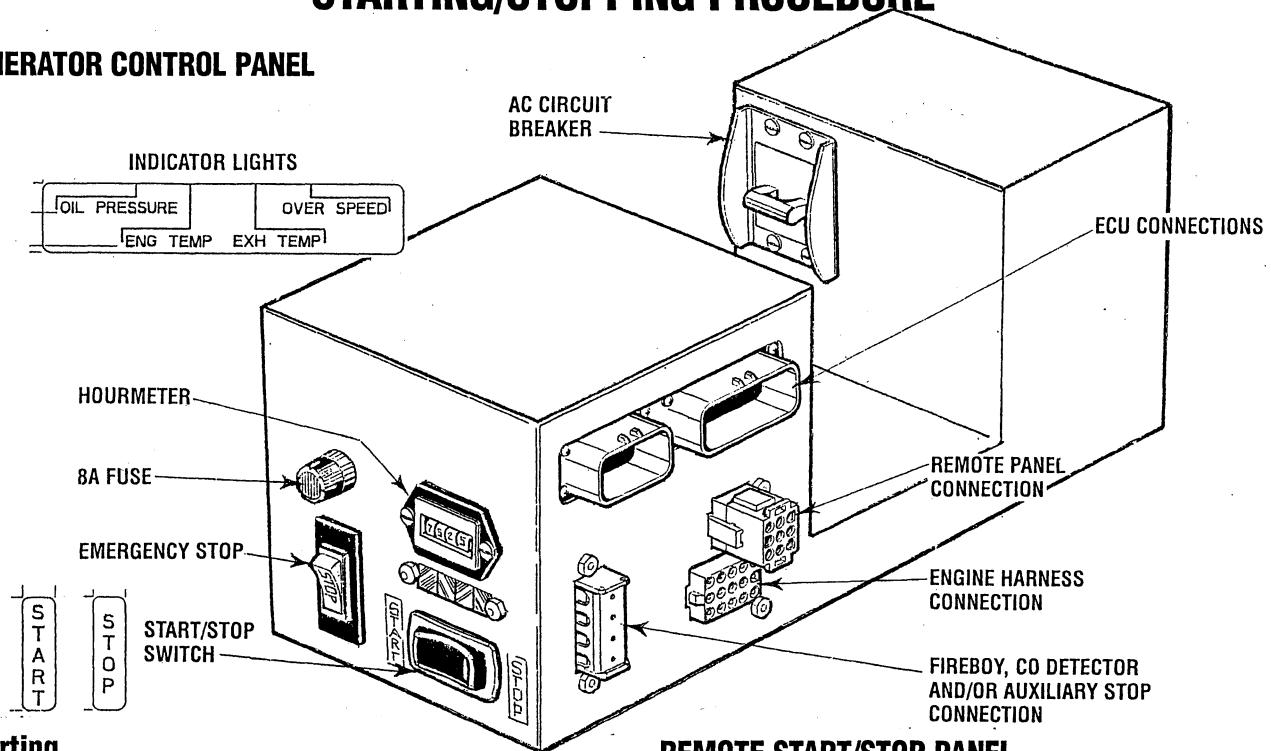

Starting

Simply press the **START** switch and the generator will start. A green light will glow indicating the generator is running.

Stopping

To stop-depress the **STOP** side of the start switch, the green light will go out and the generator is stopped.

Failure to Start

The start cycle will automatically terminate if the unit fails to start after 12-14 seconds of cranking. Wait 20 seconds, then repeat the start.

If the unit again fails to start, investigate the cause.

Sometimes after servicing the fuel system or changing the fuel filter, air can accumulate in the fuel line or the throttle body and prevent starting.

The Schrader valves on the throttle body and the fuel cell are used to remove trapped air. This air is mixed with fuel and under high pressure. Follow the **BLEEDING THE FUEL SYSTEM** instructions in this manual.

REMOTE START/STOP PANEL

The components on the panel are:

1. A three position start/stop rocker switch.
2. A green LED run indicator light on the rocker switch.
3. A four position LED fault shut down display board.

The start/stop rocker switch functions the same as the start/stop rocker switch on the generator's control panel as previously explained.

The start/stop rocker switch indicator light on the rocker switch will illuminate when the start circuit is energized. It will go dim as the engine cranks and will brighten as the engine starts to indicate the generator is running.

The LED fault shut down display board has four separate LED lights to display to the operator the cause of the generators automatic shut down. The four LED displays are: low oil pressure, high engine operating temperature, high exhaust temperature and engine over-speed/under-speed (flashes).

Should the generator shut down from one of these faults, the fault LED will remain illuminated. To reset the LED, the stop switch must be momentarily depressed.

This remote panel is a plug-in accessory and is available with a 15' to 100' wiring harness.

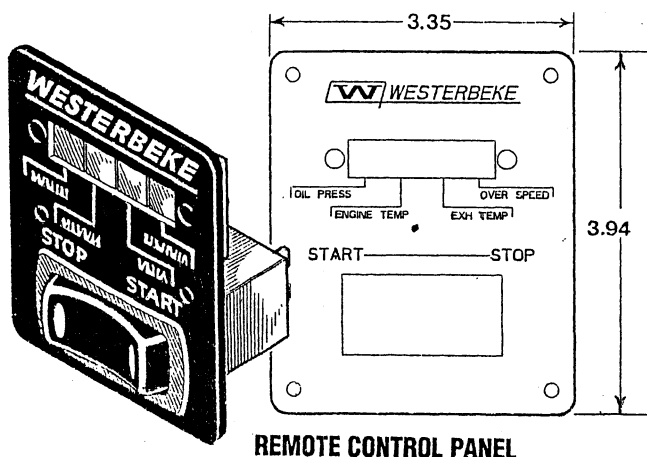

REMOTE CONTROL PANEL

CAUTION: Repeated crank cycles without a start can result in the engine's exhaust system filling with raw water. This raw water can enter the engine's cylinders by way of the exhaust manifold once the system fills. If after three crank cycles the unit does not start. Drain the system's muffler and investigate and correct the cause of no start. Engine damage the result of raw water entry is not a warrantable issue. The operator should keep this in mind.

BREAK-IN PROCEDURE/THE DAILY OPERATION

BREAK-IN PROCEDURE

After the generator has been started, check for proper operation and then encourage a fast warm-up. Run the generator between 20% and 60% of full-load for the first 10 hours.

CAUTION: Do not attempt to break-in your generator by running without a load.

After the first 10 hours of the generators operation, the load can be increased to the full-load rated output, then periodically vary the load.

Avoid overload at all times. An overload is signaled by smoky exhaust with reduced output voltage and frequency. Monitor the current being drawn from the generator and keep it within the generators rating. Since the generator operates at 1800 rpm to produce 60 hertz, control of the generator's engine break-in is governed by the current drawn from the generator.

To protect against unintentional overloading of the generator, the generator's output leads should be routed through a circuit breaker that is rated at the rated output of the generator.

NOTE: Be aware of motor starting loads and the high current drawn required for starting motors. The starting amperage drawn can be 3 to 5 times normal running amperage. See *GENERATOR INFORMATION* in this manual.

CHECK LIST

Follow this check list each day before starting your generator.

- Record the hourmeter reading in your log (engine hours relate to the maintenance schedule).
- Visually inspect the generator for fuel, oil, or water leaks.
- Check the oil level (dipstick).
- Check the coolant level in the coolant recovery tank.
- Check your fuel supply.
- Check the starting batteries (weekly).
- Check drive belts for wear and proper tension (weekly).
- Check for abnormal noise such as knocking, vibration and blow-back sounds.
- Check drive belts for wear and proper tension (weekly).
- Confirm exhaust smoke:
 - When the engine is cold – white smoke.
 - When the engine is warm – almost smokeless.
 - When the engine is overloaded – some black smoke.

NOTE: Some unstable running may occur in a cold engine. This condition should lessen as normal operating temperature is reached and loads are applied.

CAUTION: Do not operate the generator for long periods of time without a load being placed on the generator.

STOPPING THE GENERATOR

Remove the major AC liads from the generator one at a time. Allow the generator to run for a few minutes to stabilize the operating temperature and press the STOP switch down. (See *CONTROL PANELS*).

NOTE: After the first 50 hours of generator operation, check the maintenance schedule for the 50 hour service check.

GENERATOR ADJUSTMENTS

Once the generator has been placed in operation and ad break-in is/has taken place, a no-load voltage adjustment maybe needed along with a GAIN adjustment. See *VOLTAGE ADJUSTMENT* and *ECU ADJUSTMENTS* in this manual.

CAUTION: VENTILATION

Gasoline vapors can explode. Before starting the engine, operate the blower for at least four minutes and check both the engine compartment and bilge for gasoline vapors. Run the blower below cruising speed.

SAFETY SHUTDOWN SWITCHES

DESCRIPTION

The engine/generator is protected by switches and sensors that send signals to the ECU that it interprets as a fault and automatically shuts down the generator drive engine. When an automatic shutdown occurs, one of the control panel fault LED lights will illuminate indicating what fault caused the engine to shutdown. This LED will stay illuminated. To correct the fault, refer to *ENGINE TROUBLESHOOTING* in this manual. Do not attempt to restart the generator before correcting the fault.

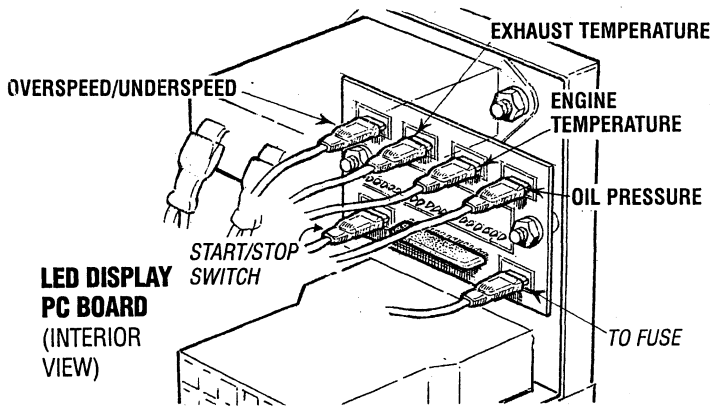

CONTROL PANEL INDICATOR LIGHTS

Four LED fault lights are located on the generator control panel and the remote start/stop panels. Should a problem occur during generator operation the individual light will indicate where the problem is and at the same time shut the generator down. The light will continue to glow after the generator shuts down. Should this occur, refer to *ENGINE TROUBLESHOOTING* in this manual.

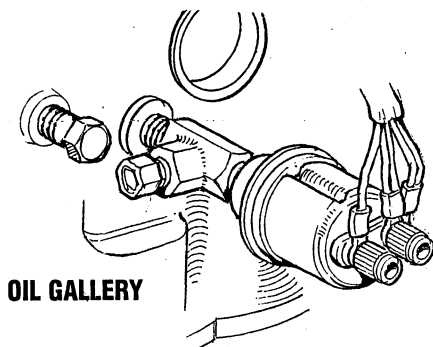

OIL PRESSURE SENSOR

An oil pressure sensor (located just below the oil filter) sends a DC voltage to the ECU that it interprets as oil pressure. Should this voltage fall below a certain level, the ECU will shut the generator down and illuminate the low oil pressure LED. Should this occur, refer to *ENGINE TROUBLESHOOTING* in this manual.

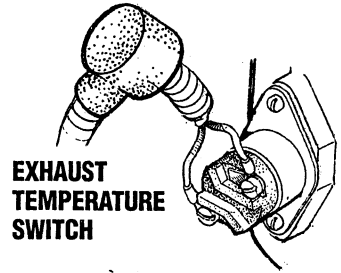

EXHAUST TEMPERATURE SWITCH

A temperature switch is mounted on the exhaust elbow to monitor the temperature of the exhaust coolant and gasses. Should the switch sense an excessive exhaust temperature, the ECU will shut the generator down and the exhaust temperature LED will illuminate on the control panel. Should this occur, refer to *ENGINE TROUBLESHOOTING* in this manual.

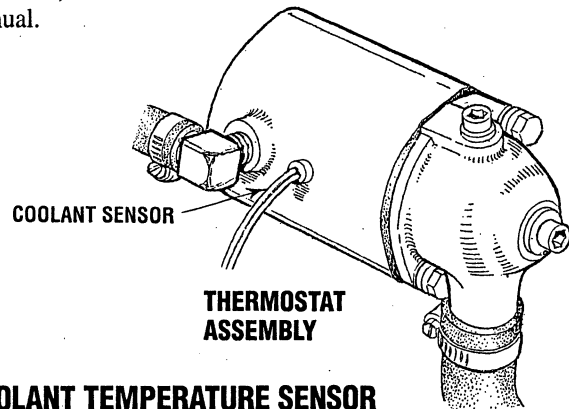

COOLANT TEMPERATURE SENSOR

A coolant temperature sensor is located on the thermostat housing to monitor the engine's fresh water coolant. Should the coolant temperature reach 210°F, the ECU will shut the generator down and the engine temperature LED will illuminate. Should this occur, refer to *ENGINE TROUBLESHOOTING* in this manual.

OVERSPEED SWITCH

An overspeed high RPM shutdown sensor in the ECU will shut the engine down if the engine RPM'S exceed the set limit and the LED will remain lit. If an underspeed problem occurs, the engine will shutdown and the LED will remain flashing.

DC CIRCUIT BREAKER

The generator's engine is protected by a panel mounted manual reset circuit breaker (20 amp). An electrical overload in the engine's wiring harness or the instrument panel will trip this breaker and shutdown the engine/generator. If this should occur, inspect and repair the problem. then reset the breaker and restart the engine/generator.

MAINTENANCE SCHEDULE

⚠ WARNING: *Never attempt to perform any service while the engine is running. Wear the proper safety equipment such as goggles and gloves, and use the correct tools for each job. Disconnect the battery terminals when servicing any of the engine's DC electrical equipment.*



Maintenance items that are very important to the proper operation of "Safe CO" generators.

SCHEDULED MAINTENANCE	CHECK EACH DAY	HOURS OF OPERATION							MAINTENANCE DESCRIPTION
		50	100	250	500	750	1000	1250	
Fuel Supply	<input type="checkbox"/>								Unleaded gasoline with octane rating of 89 or higher
Fuel/Water Separator	<input type="checkbox"/>								Check for water and dirt in fuel (drain/replace filter if necessary).
Engine Oil Level	<input type="checkbox"/>								Oil level should indicate between MAX. and LOW on dipstick.
Coolant Level	<input type="checkbox"/>								Check at recovery tank; if empty, check at manifold. Add coolant if needed.
Drive Belts	<input type="checkbox"/> weekly								Inspect for proper tension (3/8" to 1/2" deflection) and adjust if needed. Check belt edges for wear.
Visual Inspection of Engine	<input type="checkbox"/>	NOTE: <i>Keep engine surface clean. Dirt and oil will inhibit the engine's ability to remain cool.</i>							Check for fuel, oil and water leaks. Inspect wiring and electrical connections. Keep bolts & nuts tight. Check for loose belt tension.
Sparks Plugs <small>SAFE CO</small>		<input type="checkbox"/>		<input type="checkbox"/>	<input type="checkbox"/>	<input type="checkbox"/>	<input type="checkbox"/>	<input type="checkbox"/>	Check gap, inspect for burning and corrosion.
Starting Batteries (and House Batteries)	<input type="checkbox"/> weekly								Every 50 operating hours check electrolyte levels and make sure connections are very tight. Clean off excessive corrosion.
Engine Oil		<input type="checkbox"/>	<input type="checkbox"/>	<input type="checkbox"/>	<input type="checkbox"/>	<input type="checkbox"/>	<input type="checkbox"/>	<input type="checkbox"/>	Initial engine oil and filter change at 50 hours, then change both every 100 hours.
Generator		<input type="checkbox"/>	<input type="checkbox"/>	<input type="checkbox"/>	<input type="checkbox"/>	<input type="checkbox"/>	<input type="checkbox"/>	<input type="checkbox"/>	Check that AC connections are clean and secure with no chafing-see GENERATOR INFORMATION .
Fuel Lift Pump		<input type="checkbox"/>							Periodically inspect for leaks, electrical connections are clean and tight.
Air Screen <small>SAFE CO</small>		<input type="checkbox"/>							Clean at 50 hrs., then every 100 hours.
Exhaust System		<input type="checkbox"/>		<input type="checkbox"/>		<input type="checkbox"/>		<input type="checkbox"/>	Initial check at 50 hours, then every 250 hours. Inspect for leaks. Check anti-siphon valve operation. Check the exhaust elbow for carbon and/or corrosion buildup on inside passages; clean and replace as necessary. Check that all connections are tight.
Engine Hoses		<input type="checkbox"/>	<input type="checkbox"/>	<input type="checkbox"/>	<input type="checkbox"/>	<input type="checkbox"/>	<input type="checkbox"/>	<input type="checkbox"/>	Hose should be hard & tight. Replace if hoses become spongy. Check and tighten all hose clamps.
Raw Water Pump				<input type="checkbox"/>		<input type="checkbox"/>		<input type="checkbox"/>	Remove the pump cover and inspect for wear. Inspect impeller, cam and wear plate. Replace gasket. Lubricate impeller when reassembling.
Heat Exchanger		<input type="checkbox"/>	<input type="checkbox"/>	<input type="checkbox"/>	<input type="checkbox"/>	<input type="checkbox"/>	<input type="checkbox"/>	<input type="checkbox"/>	Clean or replace anode. Open heat exchanger end cap and clean out debris. Remove every 1000 hours for professional cleaning and pressure testing.
Coolant System					<input type="checkbox"/>		<input type="checkbox"/>		Drain, flush, and refill cooling system with appropriate antifreeze mix.
Fuel Filter			<input type="checkbox"/>	<input type="checkbox"/>	<input type="checkbox"/>	<input type="checkbox"/>	<input type="checkbox"/>	<input type="checkbox"/>	Change every 250 operating hours.
Inlet Fuel Filter			<input type="checkbox"/>	<input type="checkbox"/>	<input type="checkbox"/>	<input type="checkbox"/>	<input type="checkbox"/>	<input type="checkbox"/>	Change every 250 operating hours.

(continued)

MAINTENANCE SCHEDULE

NOTE: Use the engine hourmeter gauge to log your engine hours or record your engine hours by running time.

SCHEDULED MAINTENANCE	CHECK EACH DAY	HOURS OF OPERATION							MAINTENANCE DESCRIPTION
		50	100	250	500	750	1000	1250	
*Starter Motor					<input type="checkbox"/>			<input type="checkbox"/>	Check solenoid and motor for corrosion. Remove and lubricate. Clean and lubricate the starter motor pinion drive.
Distributor <small>SAFE CO</small>		<input type="checkbox"/>			<input type="checkbox"/>				Check ignition timing. Check condition of distributor cap and rotor.
*Engine Cylinder Compression and Valve Clearances					<input type="checkbox"/>			<input type="checkbox"/>	Incorrect valve clearance will result in poor engine performance, check compression pressure and timing and adjust valve clearances.
*Engine Timing Belt					<input type="checkbox"/>				Remove and replace every 1000 hours. NOTE: Failure to replace the timing belt at the recommended interval could result in timing chain failure resulting in major damage to the engine.
*Exhaust Elbow					<input type="checkbox"/>				Test exhaust elbow for casting integrity. Replace if casting is corroded or deteriorated. NOTE: A defective exhaust elbow can cause carbon monoxide leakage!
Catalytic Converter <small>SAFE CO</small>								<input type="checkbox"/>	Remove water injected exhaust elbow and visually inspect. Replace every 2000 hours.
*Exhaust System Back Pressure					<input type="checkbox"/>				Perform back pressure test to ensure system is not developing restrictions that will increase pressure above 1.5 PSI or 41 inches of water column at full operating amperage load. Correct as needed.
Catalyst <small>SAFE CO</small>								<input type="checkbox"/>	Remove water injected exhaust elbow and visually inspect every 2000 hours. Replace as needed.
Oxygen Sensor <small>SAFE CO</small>								<input type="checkbox"/>	Inspect every 1000 hours. Replace every 2000 hours.
CO in Exhaust								<input type="checkbox"/>	Sample with CO analyzer.

*WESTERBEKE recommends this service be performed by an authorized mechanic.

MEASURING EXHAUST BACK PRESSURE

Exhaust systems normally produce resistance to the flow of exhaust gases, causing back-pressure. Back-pressure must be kept within a certain limit. Check the back-pressure before the generator is put back into service.

To test exhaust pressure, connect either a water column or PSI tube to the test part on the exhaust elbow as shown.

Check the exhaust back-pressure before the generator is put into service. Measure the back-pressure after the engine has reached its normal operating temperature, and at the point where it is about to reach its rated load at either 1500 rpm (for 50Hz applications) or 1800 rpm (for 60Hz applications). Back-pressure should not exceed 1.5 psi (0.11 kg/cm²).

A water column can be made by taping one end of a clear plastic tube along a yardstick and fitting the other end of the tube with a 1/4" NPT pipe fitting.

Back-pressure should not exceed 27in (69cm) of water in the water column.

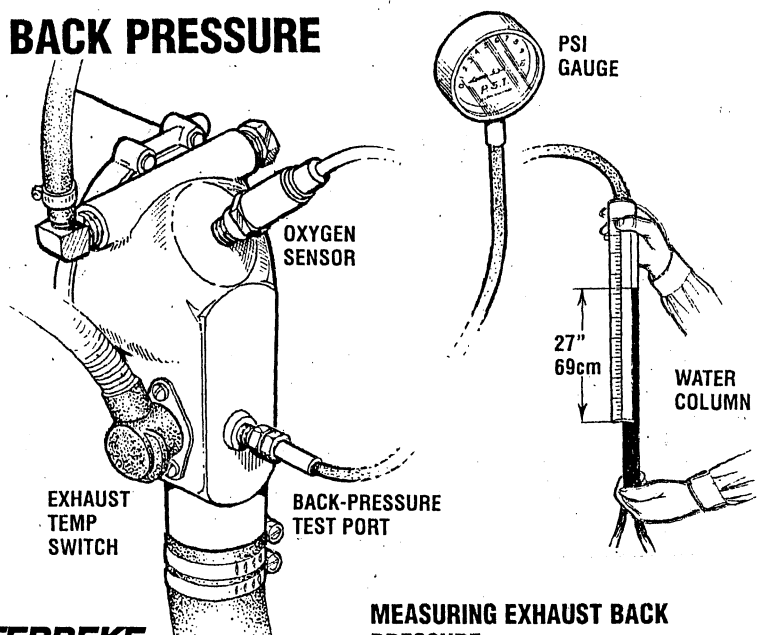

MEASURING EXHAUST BACK PRESSURE

FUEL SYSTEM

GASOLINE

Use unleaded 89 Octane gasoline or higher. Ethanol gasoline must not exceed E10 (10%). Gasoline with higher percentages of Ethanol are not acceptable for use in these models and can void the warranty.

When fueling, follow U.S. Coast Guard procedures, closing hatches and companionways to prevent fumes from entering the boat and cabins. Be sure to ventilate after fueling.

NOTE: The generator compartment should have a gasoline fume detector/alarm properly installed and working.

GASOLINE/WATER SEPARATOR AND FILTER

A primary fuel filter of the water separating type **must** be installed between the fuel tank and the engine to remove water and other contaminants from the fuel before they can be carried to the fuel system on the engine.

Most installers include a type of filter/water separator with the installation package as they are aware of the problems that contaminants in the fuel can cause.

These gasoline filters must have *metal* bowls (not "see-through") to meet U.S. Coast Guard requirements. The metal bowls have drain valves to use when checking for water and impurities.

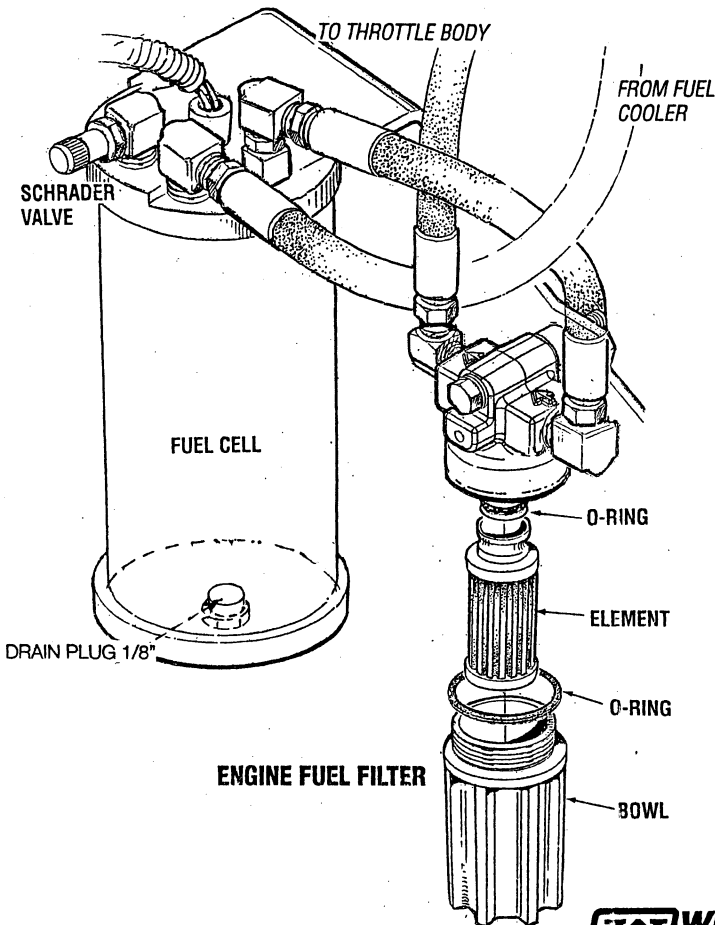
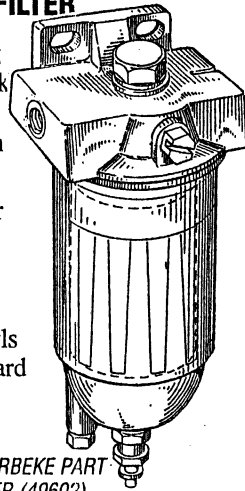

ENGINE FUEL FILTER

Periodically check the fuel connections and the bowl for leakage. Replace the filter element after the first 50 hours then follow the *MAINTENANCE SCHEDULE*.

Changing Filter Element

1. Shut the fuel supply to the generator off.
2. Ensure there is no pressure in the fuel system by bleeding off any existing pressure using a Schrader valve on the throttle body and fuel cell. Use a pressure testing kit as shown on the next page.
3. Unscrew the fuel bowl from the housing and allow the bowl to come away from the housing.
4. Remove and replace the filter element and clean the bowl.
5. Inspect both "O" rings. Replace if necessary.
6. Press on a new filter and replace the filter bowl.
7. Open the fuel supply. Inspect for leaks.

INLET FUEL FILTER

1. Shut off the fuel supply to the generator. Disconnect the fuel supply line to the inlet filter and unscrew the filter from the pump inlet. Take care to catch any fuel that may be present.
2. Thread on the replacement inlet filter and connect the fuel supply line. Use care when connecting and tightening the fuel supply line so as not to distort the inlet filter.
3. Turn on the fuel supply to the generator and start the generator. Ensure that there are no leaks.

FUEL PUMP

Periodically check the fuel connections to and out of the pump and make sure that no leakage is present and that the fittings are tight and secure. The engine mounted fuel pump is maintenance free.

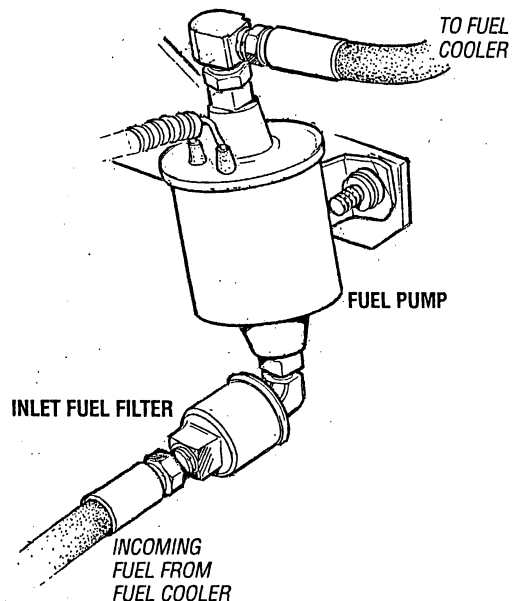

NOTE: It is recommended that the fuel system be bled during each oil and filter change interval to ensure no air has accumulated in the fuel system.

FUEL SYSTEM

BLEEDING THE FUEL SYSTEM

1. Insure that the fuel cell *is not* connected to the wiring harness, and that the lift pump *is* connected.
2. Attach Snap On MT337B, OTC 7211 or equivalent fuel pressure gauge set to the Schrader valve on fuel cell.

CAUTION: Follow manufacturer's instructions for safe use of the gauge sets to purge a high-pressure fuel system.

3. While holding the stop switch in the (prime) depressed position, purge the air from the fuel cell. The fuel cell is purged when no air bubbles are visible escaping from the drain line attached to the Schrader valve. Pressure should typically be 3-4 psi.
4. Remove the pressure gauge set from the fuel cell and connect it to the Schrader valve on the throttle body.
5. Connect the fuel cell to the wiring harness.
6. Open the valve on the fuel pressure gauge purge line. Do not prime the system without the fuel gauge purge valve open or air can be forced back into the fuel cell. If this happens, repeat steps 1, 2, and 3 to remove the trapped air from the fuel cell.
7. Repeat step 3, this time purging the air completely from the throttle body. The pressure should be 40 psi in the throttle body after purging the system.

NOTE: The system can develop 40 psi without being fully purged. The system is fully purged when no bubbles are visible in the purge line.

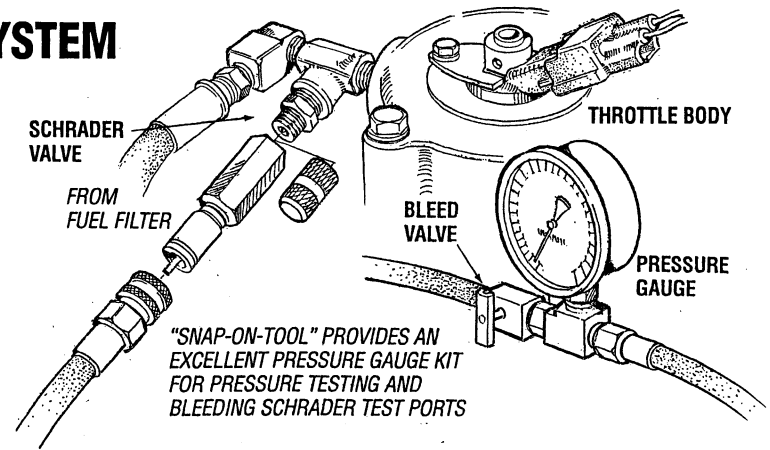

8. Remove the pressure gauge set, and cap all Schrader valves.
9. Insure that all wire connections are secure and that there are no leaks in the fuel system.

WARNING: Take care to catch any fuel that may be spilled and properly dispose of the fuel rags.

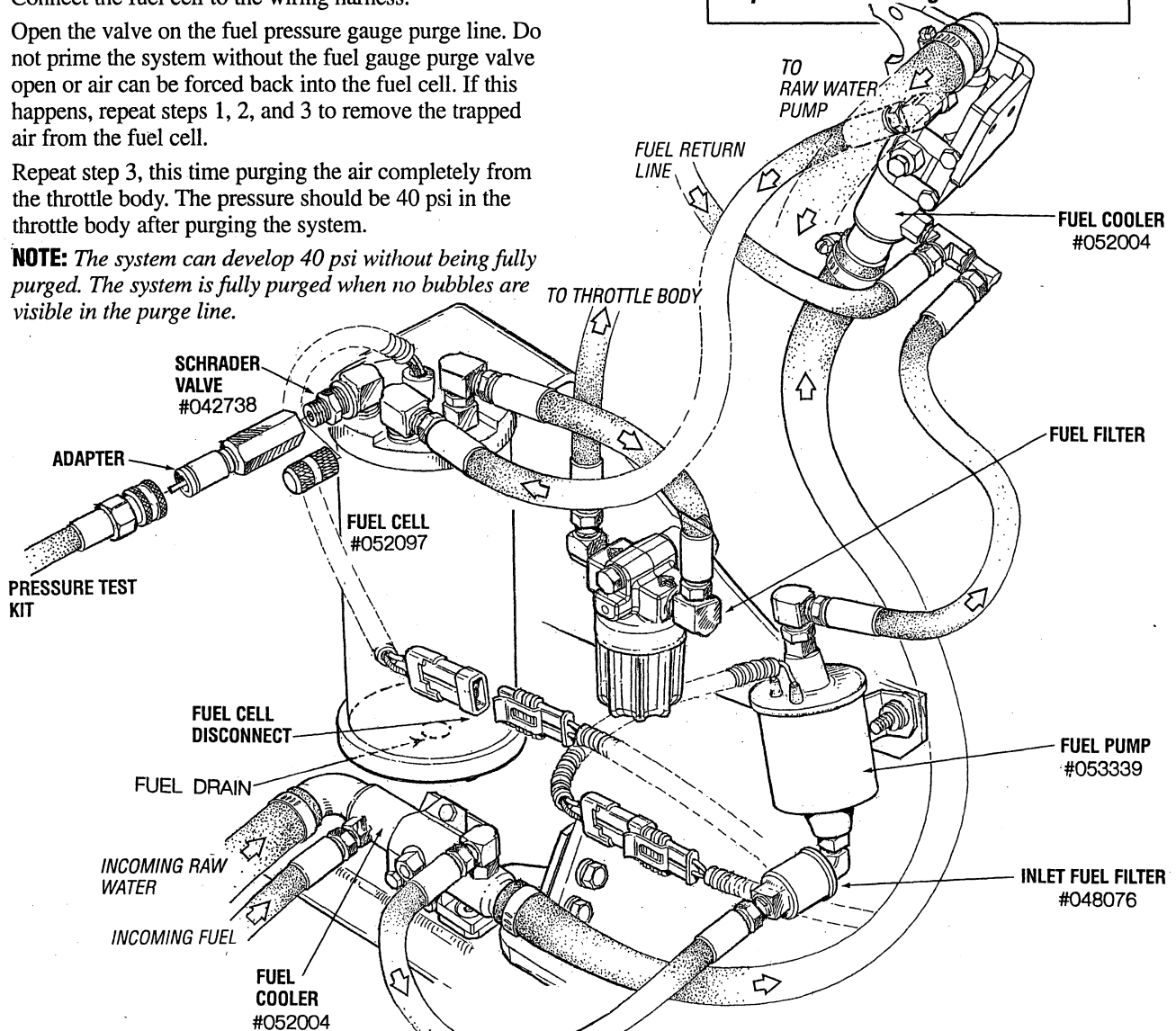

ELECTRONIC FUEL INJECTION

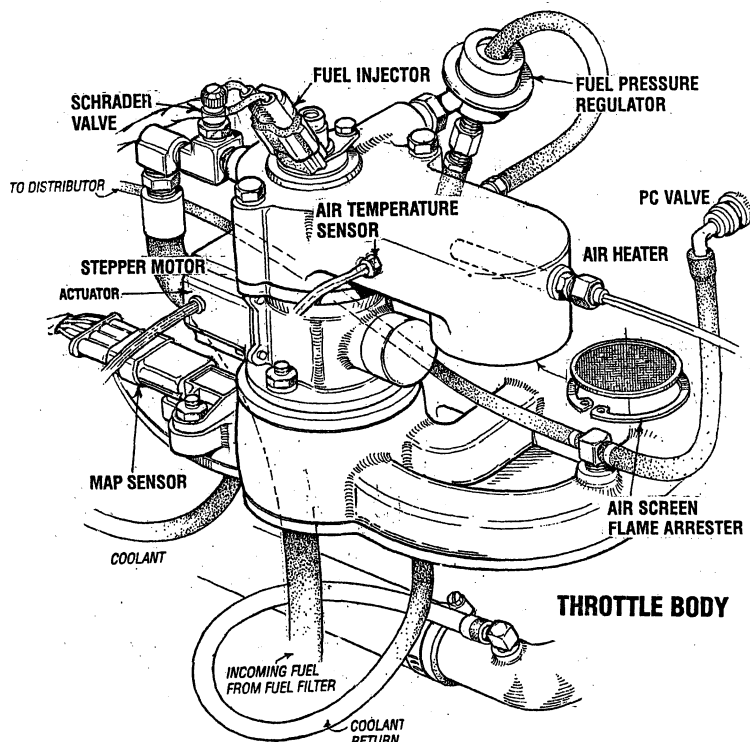

The above illustration shows the throttle body assembly that attaches to the intake manifold.

An electronic control unit (ECU) controls the fuel injector and the stepper motor.

The ECU is supplied with engine operating conditions from sensors that monitor intake air temperature, engine coolant temperature, map sensor (intake manifold absolute pressure), engine rpm and battery voltage.

The ECU interprets this information to determine the appropriate injector pulse rate and throttle opening position.

A high pressure fuel pump supplies fuel to the area around the injector and the regulator maintains the fuel pressure in that area at 35 - 40 PSI maximum.

The injector is a solenoid operated pintle valve that meters fuel into the intake manifold depending on engine operating conditions and generator amperage load determined by the ECU.

Air flow into the intake manifold is controlled by the ECU operation of the throttle plate via the stepper motor. Throttle plate positioning for proper air flow into the engine is accomplished through the ECU interpretation of engine operating conditions. The Schrader valve is used to monitor/check fuel pressure around the fuel injector.

ELECTRONIC CONTROL UNIT (ECU)

The ECU (Electronic Control Unit) is factory programmed and requires no adjustments by the generator operator. It controls all starting, operating and safety shutdown features on the engine. The Gain Pot is set at #50 midpoint for optimum system response.

Dipswitch #1 is used to change the generators frequency. ON is for 50 hertz and OFF is for 60 hertz operation. The remaining switches #2, 3#, and #4 service no functions.

NOTE: When changing the generator frequency, turn OFF the DC 20 amp breaker before moving the dipswitch.

The vacant program connector is used by the factory to input the operating program into the ECU. This connector can be used with software to monitor the operation of the Safe CO system. Contact your MD to obtain free software.

The electrical connections from the engine electrical harness are made to the ECU through two plug connections, one 23 pin and one 35 pin and may therefore vary in number according to the generator model. For further details, consult the engine circuit wiring diagram in this manual.

The ECU is normally set for operation at 60Hz unless specified otherwise, and is internally configured for a 4 pole generator. If it is necessary to replace the ECU, make sure it is configured by label for the generator in use.

ECU ADJUSTMENTS

Stability Trim (Gain)

When changing engine speed, or if no engine hunting condition should occur, the gain pot may require adjustment. There is no specific set point for this adjustment and it is normally set to the middle of its range or to a point in its range which obtains optimal engine speed response without any tendency of hunting.

Setting Engine Speed

The engine speed can be set for operation at either 50 or 60 Hz. Corresponding engine speeds for a 4 pole generator are 1500 rpm or 1800 rpm.

1. Set up whatever equipment is to be used to measure engine speed or generator output frequency.
2. Start up and run the generator at the current operating speed and frequency.
3. Adjust the GAIN setting between 40 - 60 for best system reaction to AC amperage load changes.

NOTE: A higher GAIN adjustment can induce unstable engine operation. In such cases, lessen the GAIN adjustment.

Replacing the ECU

Remove the control box cover. Before attempting to remove the ECU, turn OFF the 20 amp DC control panel breaker.

Unplug the two engine harness connections. Then unscrew the four side screws securing the ECU and remove it from it's holder. To install a new ECU, reverse the procedure.

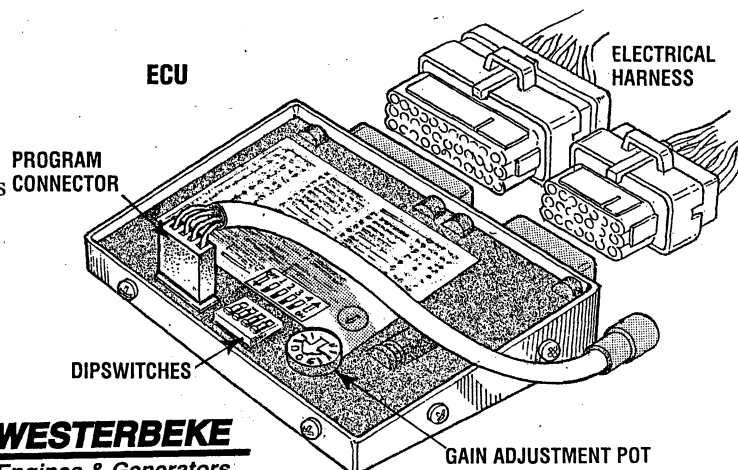

COOLING SYSTEM

FRESH WATER CIRCUIT

NOTE: Refer to ENGINE COOLANT section for the recommended antifreeze and water mixture to be used as the fresh water coolant.

Fresh water coolant is pumped through the engine by a circulating pump, absorbing heat from the engine. The coolant then passes through the thermostat into the manifold, to the heat exchanger where it is cooled and returned to the engine block via the suction side of the circulating pump. When the engine is started cold, external coolant flow is prevented by the closed thermostat (although some coolant flow is bypassed around the thermostat to prevent the exhaust manifold from overheating). As the engine warms up, the thermostat gradually opens, allowing full flow of the engine's coolant to flow unrestricted to the external portion of the cooling system.

Coolant Recovery Tank

The coolant recovery tank allows for engine coolant expansion and contraction during engine operation, without the introduction of air into the cooling system. This tank should be located at or above the engine manifold level and should be easily accessible.

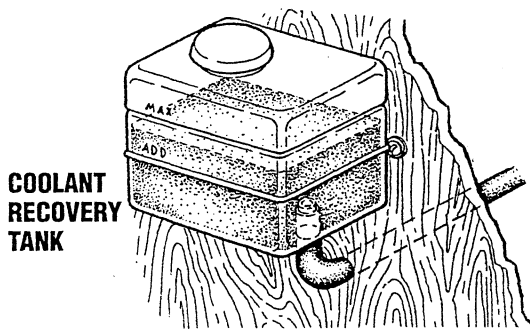

COOLANT RECOVERY TANK

NOTE: Periodically check the condition of the manifold pressure cap, its rubber seals and the vacuum return valve. Ensure the passage from the filler neck to the recovery tank connection is kept clear.

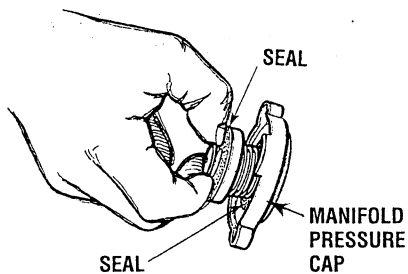

CHANGING COOLANT

The engine's coolant must be changed according to the MAINTENANCE SCHEDULE. If the coolant is allowed to become contaminated, it can lead to overheating problems.

CAUTION: Proper cooling system maintenance is critical; a substantial number of engine failures can be traced back to cooling system corrosion.

Drain the engine coolant by removing the block drain plug (right side of the block just above the oil pressure sensor) and opening the manifold pressure cap. Flush the system with fresh water, then reinstall the drain plug and refill the system.

NOTE: The drain plug on the heat exchanger can also be used to drain engine coolant.

WARNING: Beware of the hot engine coolant. Wear protective gloves.

Refilling the Coolant

After replacing the engine block drain plug, close the heat exchanger's coolant petcock. Slowly pour clean, premixed antifreeze coolant into the water jacketed exhaust manifold filler neck opening. Fill the system full, then start the engine.

Monitor the coolant in the manifold and add as needed. Fill the manifold to the filler neck and install the manifold pressure cap.

Remove the cap on the coolant recovery tank and fill with coolant mix to halfway between LOW and MAX and replace the cap. Run the engine and observe the coolant expansion flow into the recovery tank.

After checking for leaks, stop the engine and allow it to cool. Coolant should draw back into the cooling system as the engine cools down. Add coolant to the recovery tank if needed and check the coolant in the manifold. Clean up any spilled coolant.

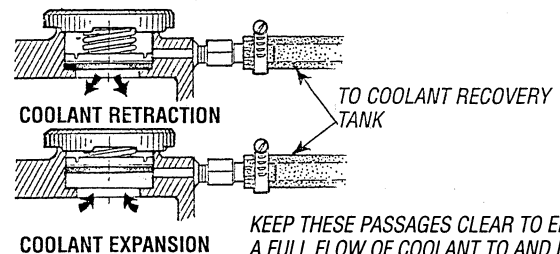

KEEP THESE PASSAGES CLEAR TO ENSURE A FULL FLOW OF COOLANT TO AND FROM THE COOLANT RECOVERY TANK (A PIPE CLEANER WORKS WELL)

COOLING SYSTEM

HEAT EXCHANGER

Cool raw water flows through the inner tubes of the heat exchanger. As the engine coolant passes around these tubes the heat of the internal engine is conducted to the raw water which is then pumped into the exhaust system and discharged. The engine coolant (now cooled) flows back through the engine and the circuit repeats itself.

The engine coolant and raw water are independent of each other, this keeps the engine's water passages clean from the harmful deposits found in raw water.

Heat Exchanger Service

After approximately 1000 hours of operation, remove, clean and pressure test the engine's heat exchanger. (A local automotive radiator shop should be able to clean and test the heat exchanger.)

NOTE: Operating in silty and/or tropical waters may require that a heat exchanger cleaning be performed more often than every 1000 hours.

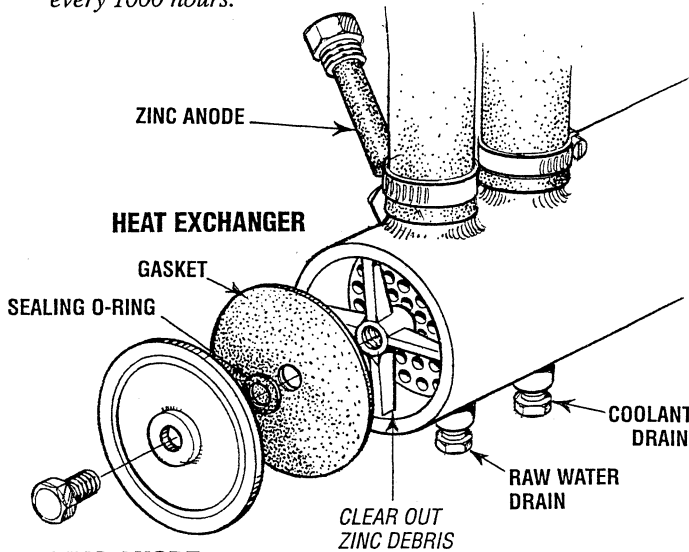

ZINC ANODE

A zinc anode, or *pencil*, is located in the raw water cooling circuit within the heat exchanger. The purpose of having zinc anodes is to sacrifice them to electrolysis action taking place in the raw water cooling circuit, thereby reducing the effects of electrolysis on other components of the system. The condition of the zinc anode should be checked monthly and the anode cleaned or replaced as required. Spare anodes should be carried on board.

NOTE: Electrolysis action is the result of each particular installation and vessel location; not that of the engine.

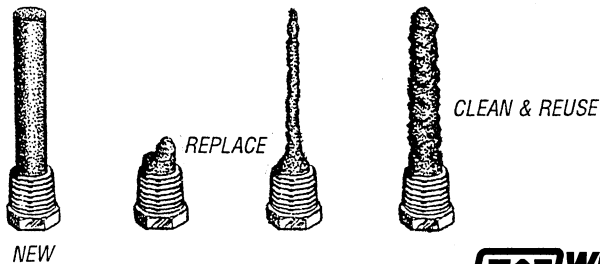

ZINC ANODES

If the zinc anodes need replacement, hold the hex boss into which the zinc anode is threaded with a wrench while loosening the anode with another wrench. This prevents the hex boss from possibly tearing off the exchanger shell. If the zinc is in poor condition, there are probably a lot of zinc flakes within the exchanger. Remove the end of the heat exchanger and clean the inside of all zinc debris. Always have a spare heat exchanger end gasket in case the present one becomes damaged when removing the end cover. Replace the gasket (refer to your engine model's heat exchanger end gasket part number), O-ring and cover, and install a new zinc anode.

NOTE: The threads of the zinc anodes are pipe threads and do not require sealant. Sealant should not be used as it may insulate the zinc from the metal of the heat exchanger housing preventing electrolysis action on the zinc.

THERMOSTAT

A thermostat, located near the manifold at the front of the engine, controls the coolant temperature as the coolant continuously flows through the closed cooling circuit. When the engine is first started, the closed thermostat prevents coolant from flowing (some coolant is by-passed through a hole in the thermostat to prevent the exhaust manifold from overheating). As the engine warms up, the thermostat gradually opens. The thermostat is accessible and can be checked, cleaned, or replaced easily. Carry a spare thermostat and gasket.

Replacing the Thermostat

To avoid spilling coolant, drain the coolant down below the manifold level (*REFER TO CHANGING COOLANT*). Remove the cap screws and disassemble the thermostat housing as shown. When installing the new thermostat and gasket, apply a thin coat of sealant on both sides of the gasket before pressing it into place. Do *not* over-tighten the cap screws. Replace the coolant in the manifold. Run the engine and check for normal temperatures and that there are no leaks at the thermostat housing.

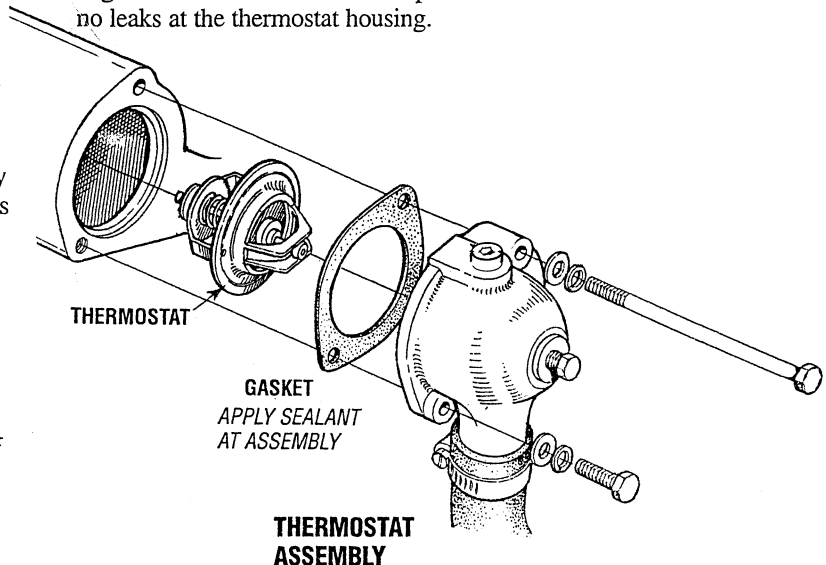

COOLING SYSTEM

RAW WATER PUMP (#42026)

The raw water pump is a self-priming, rotary pump with a non-ferrous housing and a neoprene impeller. The impeller has flexible blades which wipe against a curved cam plate within the impeller housing, producing the pumping action. **On no account should this pump be run dry as water acts as a lubricant for the impeller.** There should always be a spare impeller and impeller cover gasket (an impeller kit) aboard. Raw water pump impeller failures occur when lubricant (raw water) is not present during engine operation. Such failures are not warrantable, and operators are cautioned to make sure raw water flow is present at start-up. The neoprene impeller has a limited lifetime and must be inspected regularly.

NOTE: Should a failure occur with the pump's internal parts (seals and bearings), it may be more cost effective to purchase a new pump and rebuild the original pump as a spare.

Inspecting/Changing the Raw Water Pump Impeller

Close the raw water intake valve. Remove the pump cover and, with the proper size impeller tool, carefully pry the impeller out of the pump (the impeller can be pried out using a pair of screwdrivers if an impeller puller is unavailable. Take care not to tear the impeller). Install the new impeller and O-ring. Move the blades to conform to the curved cam plate and push the impeller into the pumps housing. When assembling, apply a thin coating of lubricant to the impeller and gasket. **Open the raw water intake valve.**

Run the engine and check for leaks around the pump. Also check for water discharge at the stern tube. Absence of water flow indicates the pump has not primed itself properly.

NOTE: Never allow the pump to run dry. Even a short period of dry running may destroy the impeller.

INSPECT THE O-RING AND IMPELLER. REPLACE IF THEY SHOW SIGNS OF WEAR.

THE PIN FITS INTO THE SLOT IN THE SHAFT.

IMPELLER

O-RING

LIGHTLY GREASE THE PUMP CHAMBER, O-RING, AND IMPELLER WITH GLYCERIN.

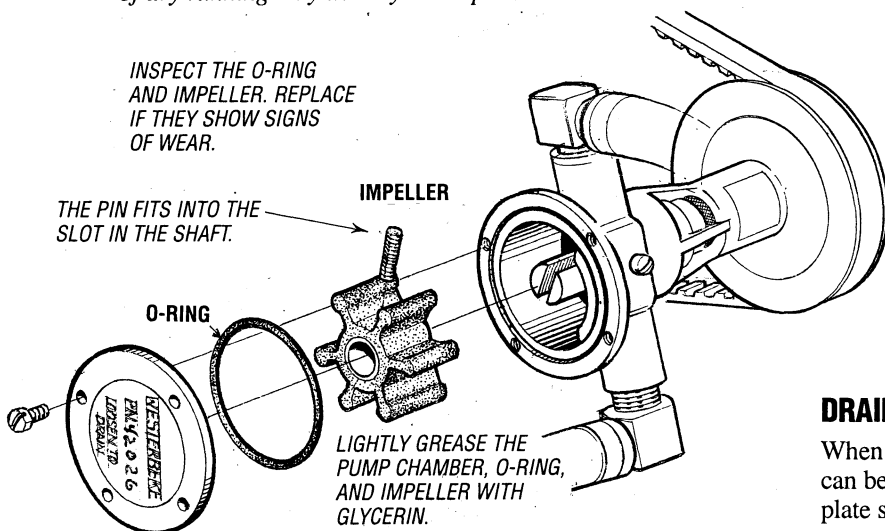

CAUTION: If any of the blades have broken off the impeller, they must be located to prevent blockage in the cooling circuit. They often can be found in the heat exchanger

RAW WATER INTAKE STRAINER

NOTE: Always install the strainer at or below the waterline so the strainer will always be self-priming.

A clean raw water intake strainer is a vital component of the engine's cooling system. Include a visual inspection of this strainer when making your periodic engine check. The water in the glass should be clear.

Perform the following maintenance after every 100 hours of operation:

1. Close the raw water seacock.
2. Remove and clean the strainer filter.
3. Clean the glass.
4. Replace the sealing washer if necessary.
5. Reassemble and install the strainer.
6. Open the seacock.
7. Run the engine and check for leaks.

NOTE: Also follow the above procedure after having run hard aground.

If the engine temperature gauge ever shows a higher than normal reading, the cause may be that silt, leaves or grass may have been caught up in the strainer, slowing the flow of raw water through the cooling system.

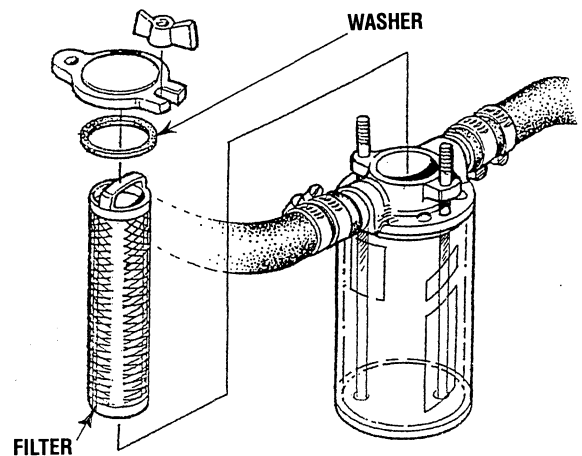

TYPICAL RAW WATER INTAKE STRAINER
(Owner Installed)

DRAINING THE RAW WATER COOLING SYSTEM

When freezing temperatures are expected, the cooling system can be drained by loosening the raw water pump's cover plate screws. This should allow the water to drain out of the pump and also drain back to the strainer.

Open the raw water petcock/plug on the heat exchanger to allow the raw water to drain.

ENGINE LUBRICATING OIL

OIL GRADE

Use a heavy duty engine oil with an API classification of SJ, SL, or SM. Change the engine oil and filter after an initial 50 hours of engine break-in operation. Then follow the oil and filter change intervals as specified in the **MAINTENANCE SCHEDULE** in this manual.

Westerbeke Corporation does not approve or disapprove the use of synthetic oils. If synthetic oils are used, engine break-in **MUST** be performed using conventional oil. Oil change intervals must be as listed in the **MAINTENANCE SCHEDULE** section in this manual and not to be extended if synthetic oils are used. SAE 15W-40 is suitable for use in all seasons.

NOTE: The information above supersedes all previous statements regarding synthetic oil usage.

CHANGING THE ENGINE OIL

The engine oil should be warm. Remove the oil drain hose from its attachment bracket and lower it into a container and allow the oil to drain, or attach a pump to the end of the drain hose and pump the old oil out. Make sure the oil drain hose is properly secured in its holder after all of the old oil has been drained.

Always observe the old oil as it is removed. A yellow/gray emulsion indicates the presence of water in the oil. Although this condition is rare, it does require prompt attention to prevent serious damage. Call a competent mechanic if water is present in the oil. Raw water present in the oil can be the result of a fault in the exhaust system attached to the engine and/or a siphoning through the water cooling circuit into the exhaust, filling into the engine.

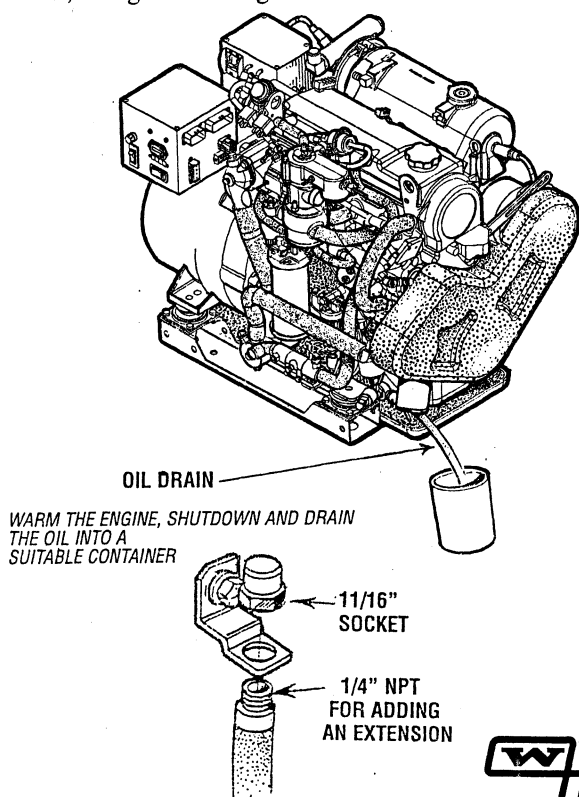

Replacing the Oil Filter

When removing the used oil filter, you may find it helpful to punch a hole in the upper and lower portion of the old filter to drain the oil into a container before removing it. This helps to lessen spillage. An automotive filter wrench should be helpful in removing the old oil filter. Place some paper towels and a plastic bag around the filter when unscrewing it to catch any oil that's in the filter. Inspect the old oil filter as it is removed to make sure that the rubber sealing gasket comes off with the old oil filter. If this rubber sealing gasket remains sealed against the oil filter adapter, gently remove it. When installing the new oil filter element, wipe the filter gasket's sealing surface on the oil filter adapter free of oil and apply a thin coat of clean engine oil to the rubber sealing gasket on the oil filter. Screw the filter onto the threaded oil filter stub, and tighten the filter firmly by hand.

NOTE: Use genuine WESTERBEKE oil filters. Generic filters are not recommended.

REFILLING THE OIL SUMP

Add fresh oil through the valve cover. After refilling the oil, run the engine for a few moments while checking the engine's oil pressure. Make sure there is no leakage around the new oil filter or from the oil drain system, and then stop the engine. Then check the quantity of oil with the lube oil dipstick. Fill to, but not over, the FULL mark on the dipstick.

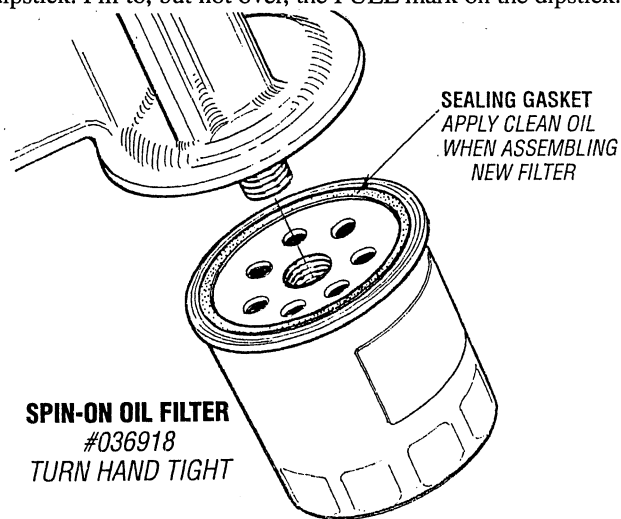

CHANGING OIL FILTER

OIL PRESSURE

The engine's oil pressure, during operation, is indicated by the oil pressure gauge on the instrument panel. During normal operation, the oil pressure will range between 40 and 60 psi (2.8 and 4.2 kg/cm²).

NOTE: A newly started, cold engine can have an oil pressure reading up to 60 psi (4.2 kg/cm²). A warmed engine can have an oil pressure reading as low as 35 psi (2.5 kg/cm²). These readings will vary depending upon the temperature of the engine and the rpms. Refer to **ENGINE ADJUSTMENT** pages for **TESTING OIL PRESSURE**.

WESTERBEKE
Engines & Generators

REMOTE OIL FILTER (OPTIONAL)

INSTALLATION

This popular accessory is used to relocate the engine's oil filter from the engine to a more convenient location such as an engine room bulkhead.

NOTE: Refer to *ENGINE OIL CHANGE* in this manual for instructions on removing the oil filter.

To install, simply remove the engine oil filter and thread on WESTERBEKE's remote oil filter kit as shown. Always install this kit with the oil filter facing down as illustrated.

Contact your WESTERBEKE dealer for more information

NOTE: Westerbeke is not responsible for engine failure due to incorrect installation of the Remote Oil Filter.

CAUTION: It is vital to install the oil lines correctly. If the oil flows in the reverse direction, the bypass valve in the filter assembly will prevent the oil from reaching the engine causing an internal engine failure. If there is no oil pressure reading, shutdown immediately and check the hose connections.

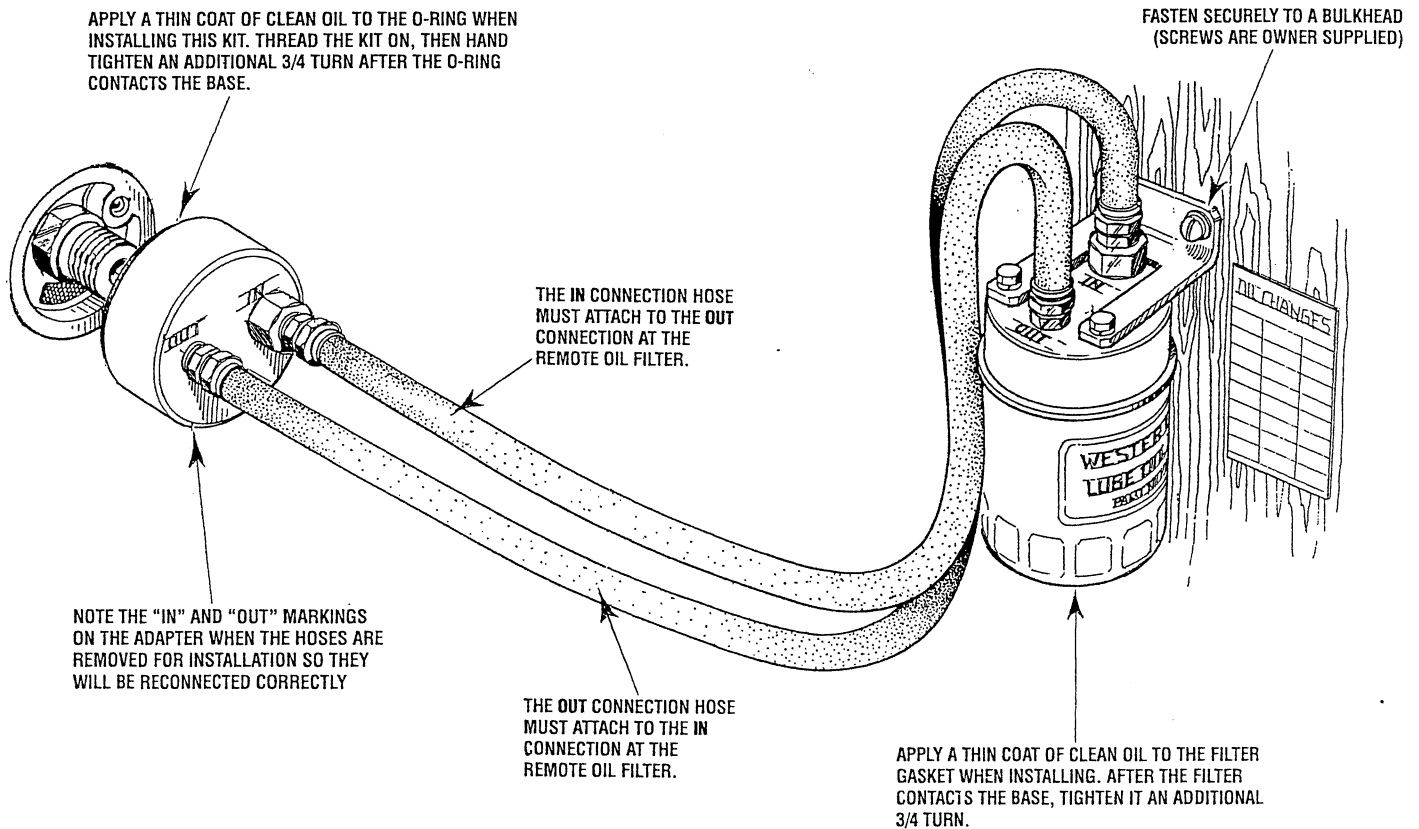

THROTTLE BODY ASSEMBLY

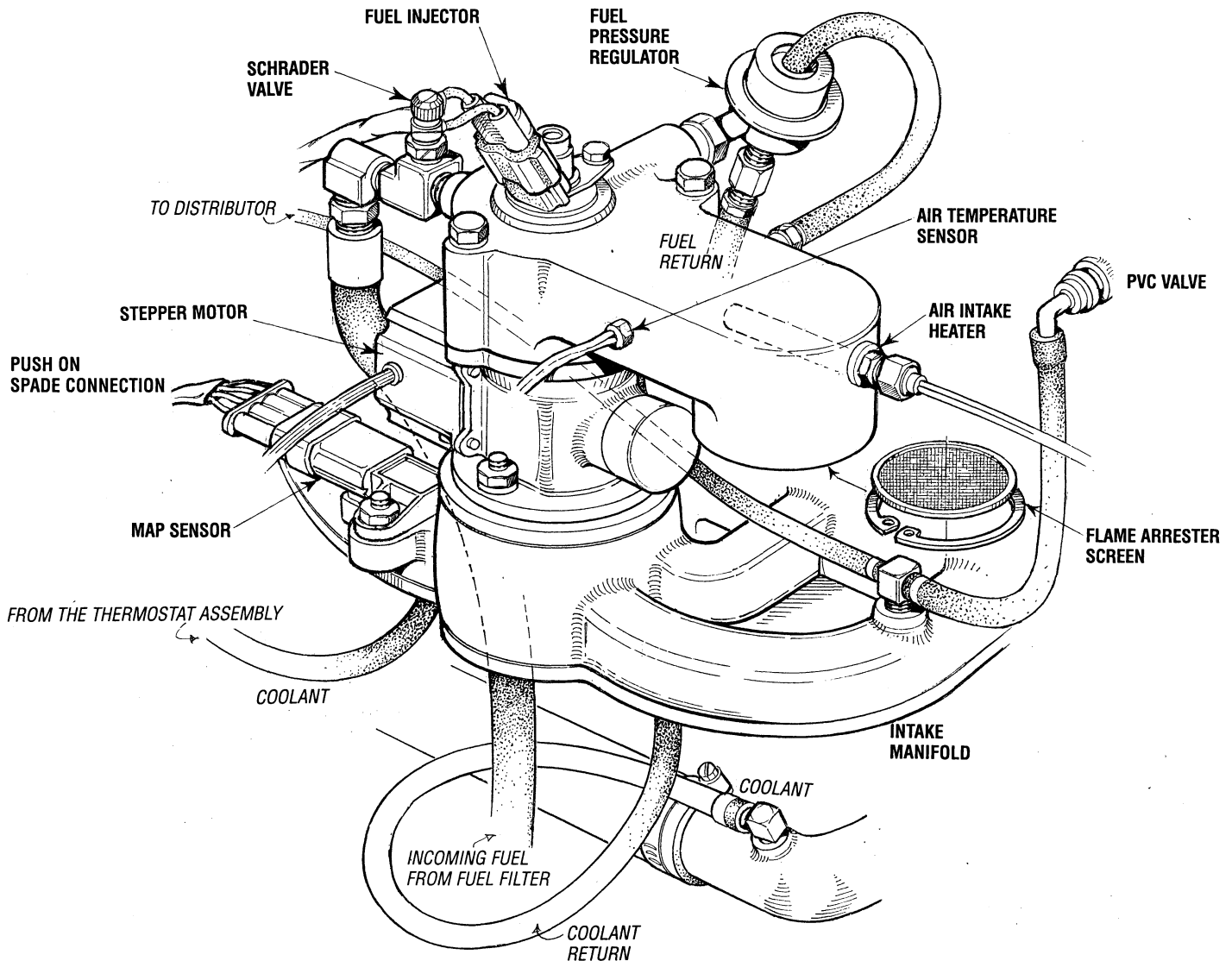

DESCRIPTION

The above illustration shows the throttle body assembly attached to the intake manifold.

An electronic control unit (ECU) controls the fuel injector and the throttle actuator.

The ECU is supplied with engine operating conditions from sensors that monitor intake air temperature, engine coolant temperature, map sensor (intake manifold absolute pressure), engine rpm and battery voltage.

The ECU interprets this information to determine the appropriate injector pulse rate and throttle opening position. A high pressure fuel pump supplies fuel to the area around the injector and the regulator maintains the fuel pressure in that area at 35 - 40 PSI.

The injector is a solenoid operated pintle valve that meters fuel into the intake manifold depending on engine operating conditions and generator amperage load as determined by the ECU.

Air flow into the intake manifold is through the flame arrester/air filter and is controlled by the ECU operation of the throttle plate via the actuator. Throttle plate positioning for proper air flow into the engine is accomplished through the ECU interpretation of engine operating conditions. The Schrader valve is used to monitor/check fuel pressure around the fuel injector and to bleed air from that area after fuel system servicing.

An air intake heater is positioned in the intake to heat the incoming air during a cold start.

ENGINE ADJUSTMENTS

SPARK PLUGS

The spark plugs should be cleaned and regapped after the first 50 hour break-in period, then inspected every 250 hours thereafter and replaced as needed.

WARNING: Do not remove the spark plugs while the engine is hot. Allow the engine to cool before removing them.

SPARK PLUG GAP: 0.031 ± 0.002 in. (0.8 – 0.05 mm).

SPARK PLUG TORQUE: 25 Nm. (18.45 ft-lb)

NOTE: Loctite Anti-Seize applied to the threaded portion of the spark plugs will retard corrosion, making future removal of the spark plugs easier.

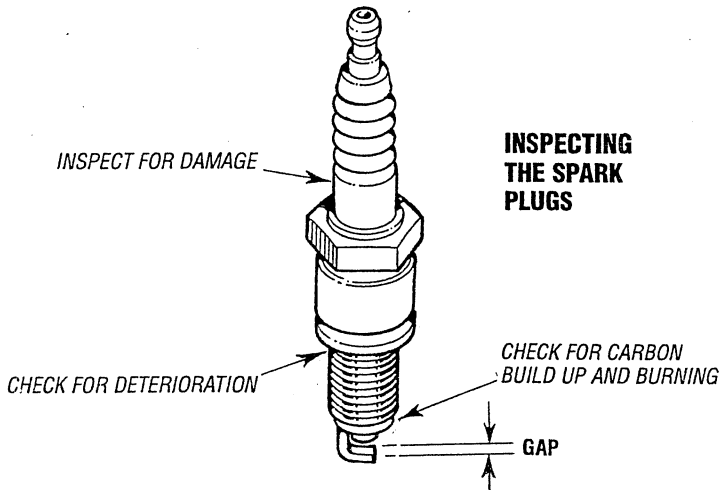

HIGH TENSION CORDS (IGNITION WIRES)

Check the ignition wires every 500 operating hours as engine compartment heat can deteriorate the wires.

Check the resistance of each wire. Do not pull on the wire because the wire connection inside the cap may become separated or the insulator may be damaged. When removing the wires from the spark plugs, grasp and twist the molded cap, then pull the cap off the spark plug.

The resistance value is 410 ohm per inch of wire.

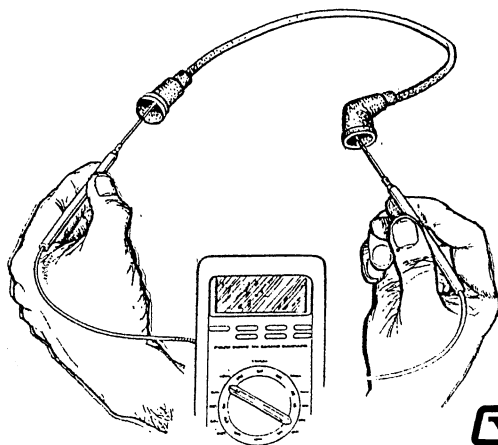

CHECKING RESISTANCE

NOTE: Properly functioning spark plugs and high tension leads play a very important part in the proper functioning of the LOW CO system. Service these components regularly.

DRIVE BELT ADJUSTMENT

The drive belts must be properly tensioned. Excessive drive belt tension can cause rapid wear of the belts and reduce the service life of the fresh water pump's bearing. A slack belt or the presence of oil on the belt can cause belt slipping, resulting in high operating temperatures.

This generator has two drive belts, one drives the governor and alternator and the other drives the raw water pump. The tension adjustment procedure for both belts is as follows:

1. Remove the belt guard.
2. To adjust the governor/alternator drive, loosen the two governor mounting bolts.

To adjust the raw water pump/fresh water pump drive belt, loosen the two raw water pump mounting bolts.

3. With the belt(s) loose, inspect for wear, cracks and frayed edges and replace if necessary.
4. To loosen or tighten the alternator drive belt, slide the alternator in or out as required, then retighten its mounting bolts.

To loosen or tighten the raw water pump/fresh water pump drive belt, slide the raw water pump in or out as required, then retighten its mounting bolts.

5. The drive belts are properly adjusted if it can be deflected no less than 3/8 inch (10mm) and no more than 1/2 inch (12mm) as the belt is depressed with the thumb at the midpoint between the two pulleys on the longest span of the belt.

WARNING: Never attempt to check or adjust a drive belt's tension while the engine is in operation.

6. Operate the engine for about 5 minutes, then shut down the engine and recheck the belts tension.
7. Replace the belt guard.

ENGINE ADJUSTMENTS

NOTE: WESTERBEKE recommends that the following engine adjustments be performed by a competent engine mechanic. The information below is provided to assist the mechanic.

ENGINE COMPRESSION TEST

1. To check the engine's compression pressure, warm up the engine then shut it down.
2. Remove the spark plugs and install a compression adapter (screws into a plug hole) with a gauge.
3. Close off the raw water intake seacock.
4. Crank the engine with the start motor and unplug the ignition coil and allow the compression gauge to reach a maximum reading and record.
5. Measure the compression pressure for all the cylinders. Ensure that compression pressure differential for each cylinder is within the specified limit.

Compression pressure should not differ by more than 14 psi (100Kpa).

6. If a cylinder's compression or pressure differential is below the limit, add a small amount of engine oil through the spark plug hole and repeat steps 3 and 4.
 - a) If addition of oil causes an increase of pressure, the piston ring and/or cylinder wall may be worn or damaged.
 - b) If additional oil does not increase compression pressure, suspect poor valve contact, valve seizure, or valve wear.
7. Re-install plugs and ignition wires.
8. Open the raw water seacock (thru-hull).

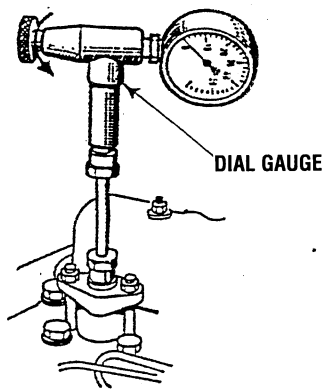

MEASURING COMPRESSION

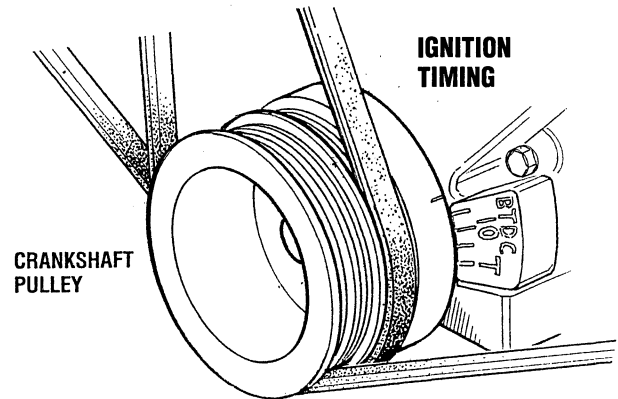

2. Start the engine and warm the engine to its normal operating temperature.
3. Using the timing light, align the timing groove in the front crankshaft pulley with the proper timing mark on the ignition timing scale embossed on the engine's front cover. Do this by loosening and slowly rotating the distributor body. refer to the timing specification:

IGNITION TIMING AT 1800 RPM:
 15° BTDC ± 1° STATIC (NO VACUUM ADVANCE)
 (33° - 35° AT NO-LOAD WITH VACUUM ADVANCE)

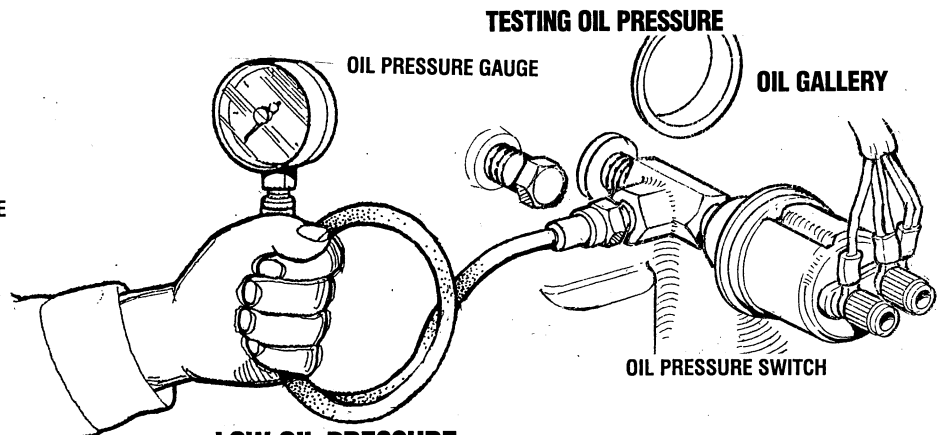

LOW OIL PRESSURE

The specified safe minimum oil pressure is 4.3 - 1.4 psi (0.3 - 0.1 kg/cm²). An oil pressure of 5 PSI will shut the engine down. A gradual loss of oil pressure usually indicates worn bearings. For additional information on low oil pressure readings, see the *ENGINE TROUBLESHOOTING* chart.

TESTING OIL PRESSURE

To test oil pressure, remove the oil gallery "T" and install a mechanical oil pressure gauge in its place. After warming up the engine, read the oil pressure gauge.

OIL PRESSURE 35.0 lb/in² (3.8 kg/cm²) or more at 1800 rpm
 (depending on temperature and load)
SENSOR AND SWITCH TORQUE 9 - 13 ft-lb (1.2 - 1.8 m-kg)

IGNITION TIMING

1. Attach a timing light to the #1 spark plug and mark the front crankshaft timing groove and the timing mark on the scale embossed on the engine's front cover.
 Each timing mark represents 5°.

ENGINE ADJUSTMENTS

NOTE: WESTERBEKE recommends that the following engine adjustments be performed by a competent engine mechanic. The information below is provided to assist the mechanic.

VALVE CLEARANCE AND ADJUSTMENT

1. Start the engine and allow it to warm up until the engine coolant reaches operating temperature.
2. Remove all the spark plugs to allow ease in rotating the engine crankshaft and to allow viewing of the piston movement.
3. Rotate the engine crankshaft to position No.1 piston at TDC of its compression stroke. Observe intake and exhaust valve movement to indicate compression stroke. Align the timing mark on the crankshaft pulley with the T mark on the gear case timing indicator. This places No.1 piston at TDC of its compression stroke. Observe the piston through the spark plug opening.
3. Start the engine and allow it to warm up until the engine coolant reaches operating temperature.
4. Note: When measuring the valve clearance, if the valve clearance is not as specified, loosen the rocker arm lock nut and adjust the clearance using a feeler gauge by turning the adjusting screw. While holding the adjusting screw with a screwdriver to prevent it from turning, tighten the lock nut to the specified torque of 15 Nm.
5. Adjust the intake and exhaust valves for Cylinder No. 1.
6. Rotate the crankshaft 90 degrees and adjust the valves for Cylinder No.3. Rotate the crankshaft another 90 degrees and adjust the valves for Cylinder No.4. Rotate the crankshaft another 90 degrees and adjust the valves for Cylinder No.2.
7. Install the rocker cover.
8. Install the spark plugs, placing a small amount of Anti-Seize on the thread of the plug. Tighten to 25 Nm.

CRANKSHAFT PULLEY

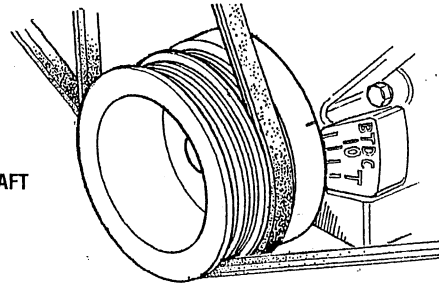

VALVE CLEARANCE (ENGINE HOT)

INTAKE 0.20 MM (0.0079 IN)
EXHAUST 0.25 MM (0.0098 IN)
FIRING ORDER 1-3-4-2

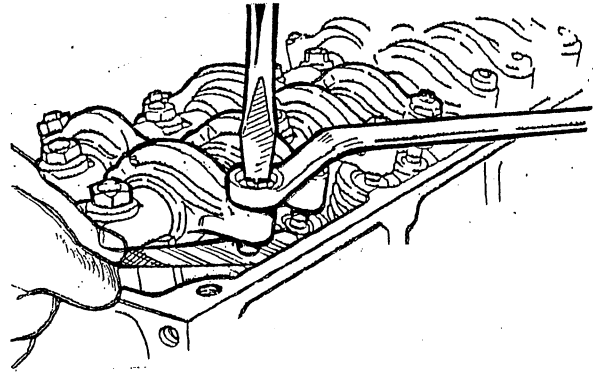

TESTING THE IGNITER

Reference the illustration below. Using AWG#16 wire, connect the igniter through a 12 VDC battery as shown. Momentarily place the tip of a metal screw driver near the middle of the pick-up of the igniter. Each time this is done, a spark should jump the gap. This will indicate a serviceable igniter.

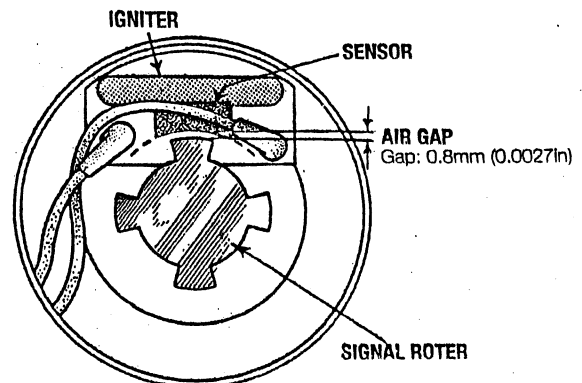
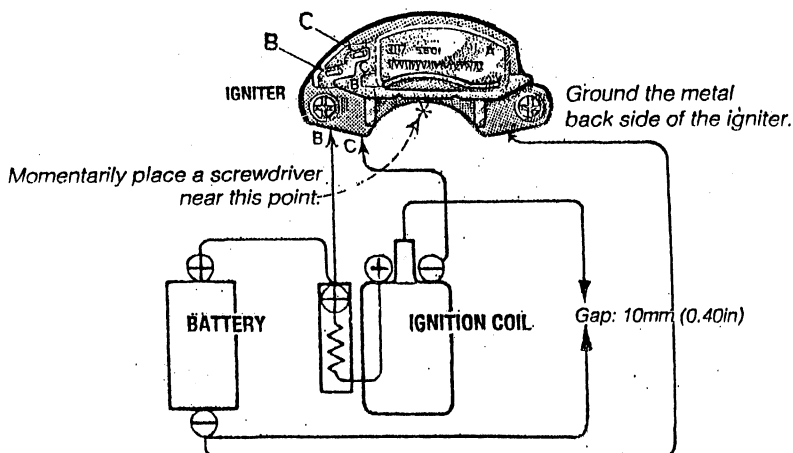

Do not mix up the wire connections to terminals B and C as that would damage the igniter.

If the distributor is operated with the external resistor left shorted, the igniter and coil will overheat.

ENGINE ADJUSTMENTS

NOTE: WESTERBEKE recommends that the following engine adjustments be performed by a competent engine mechanic. The information below is provided to assist the mechanic.

TIMING BELT INSPECTION AND REPLACEMENT

CAUTION: Water or oil on the timing belt severely reduces the service life of the belt. Keep the timing belt sprocket and tensioner free of oil and grease. These parts should never be cleaned. Replace if seriously contaminated with dirt or oil. If oil is evident on these parts, check the front case, oil pump oil seals, and crankshaft oil seals for a possible leak.

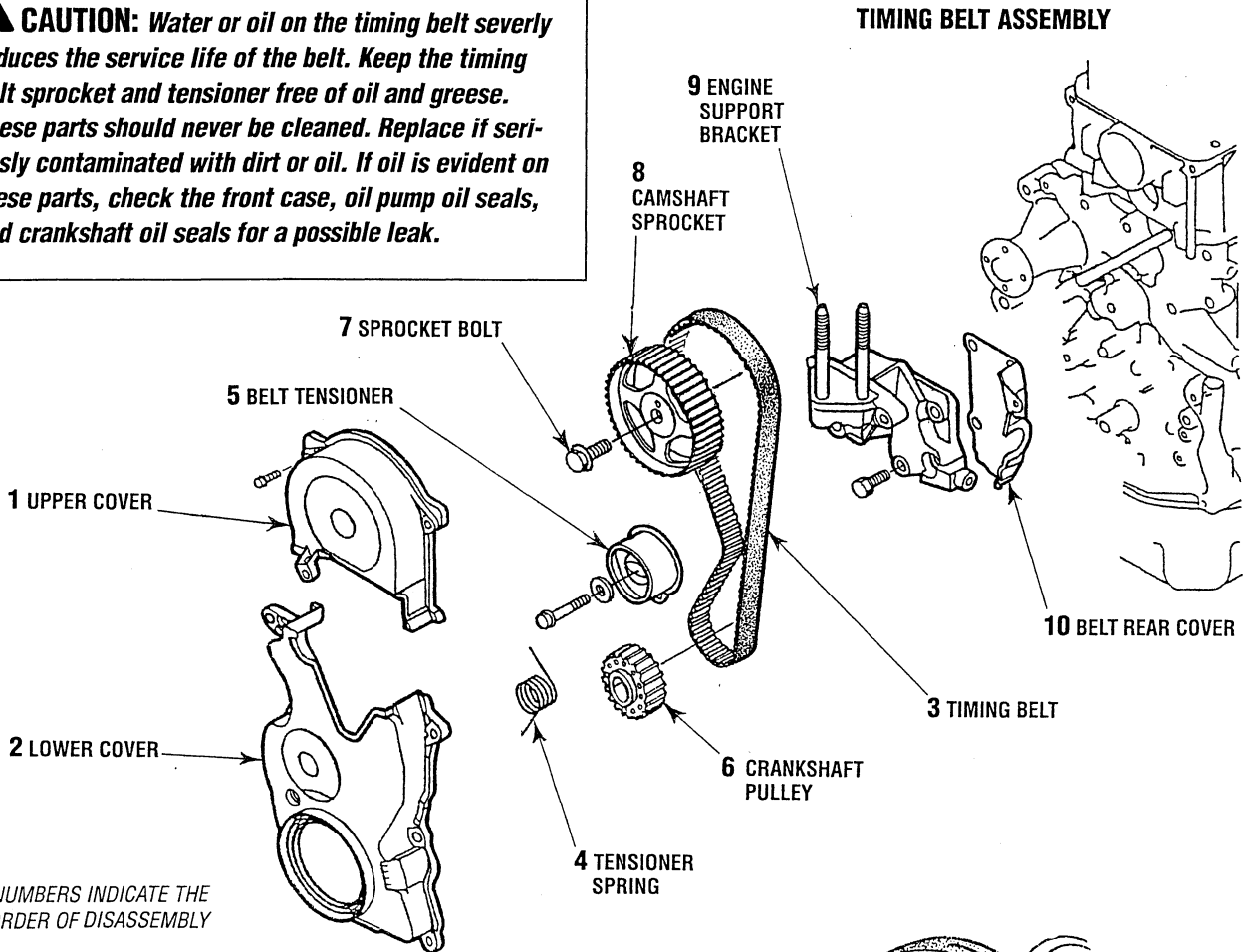

TIMING BELT REMOVAL

Using pliers, grip the tensioner spring projection and remove it from the oil pump case stopper. Then, remove the tensioner spring and the timing belt tensioner.

NOTE: If the timing belt is to be reused, chalk an arrow on the belt to indicate the direction of rotation before removing it. This will ensure the timing belt is fitted correctly when reused.

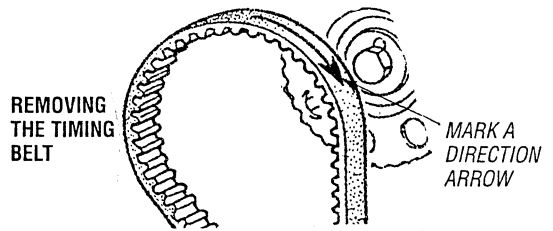
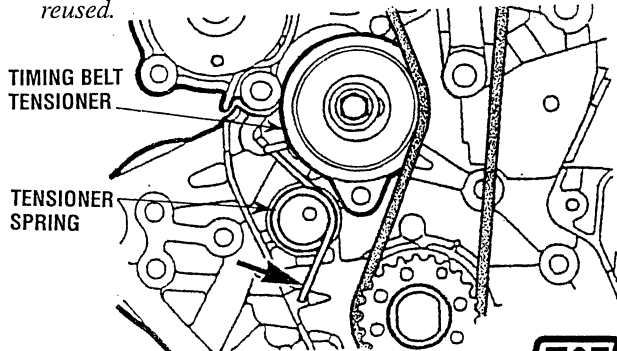

SPROCKET BOLT REMOVAL (CAMSHAFT)

Using the special tools shown in the illustration, lock the camshaft sprocket in position and then loosen the camshaft sprocket bolt.

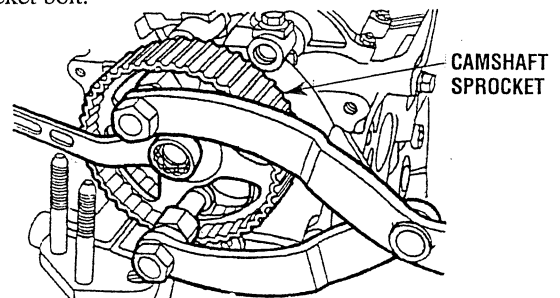

ENGINE ADJUSTMENTS

NOTE: WESTERBEKE recommends that the following engine adjustments be performed by a competent engine mechanic. The information below is provided to assist the mechanic.

Timing Belt Inspection

Replace the belt if any of the following conditions exist:

1. Hardening of back rubber-back side is glossy, without resilience, and leaves no indent when pressed with fingernail.
2. Cracks on rubber back.
3. Cracks or peeling of canvas.
4. Cracks on tooth bottom.
5. Cracks on belt.
6. Abnormal wear of belt sides. The sides are normal if they are sharp as if cut by a knife.
7. Abnormal wear on teeth.
8. Tooth missing and canvas fiber exposed.

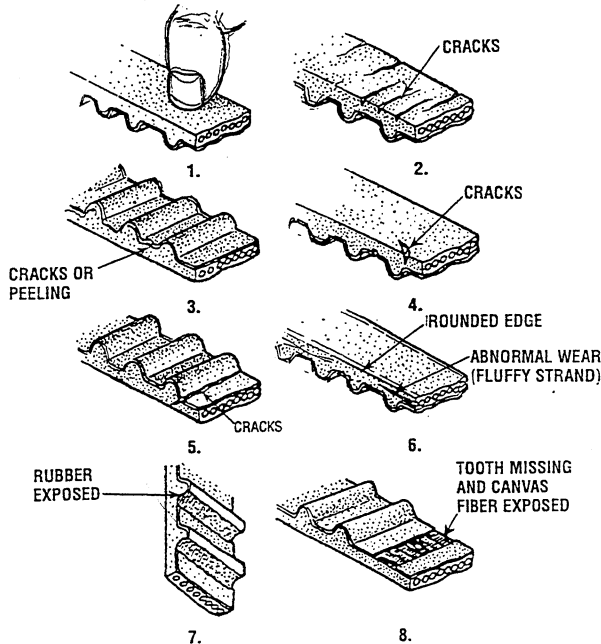

Belt Tensioner Inspection

Replace the belt tensioner if it binds, rattles, or is noisy when turned.

Tensioner Spring Installation

1. Lock the timing belt tensioner in the illustrated position.

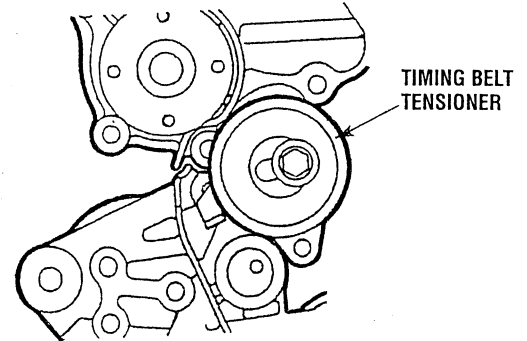

2. Fit one of the tensioner spring projections over the hooked portion of the belt tensioner and fit the tensioner onto the oil pump case.

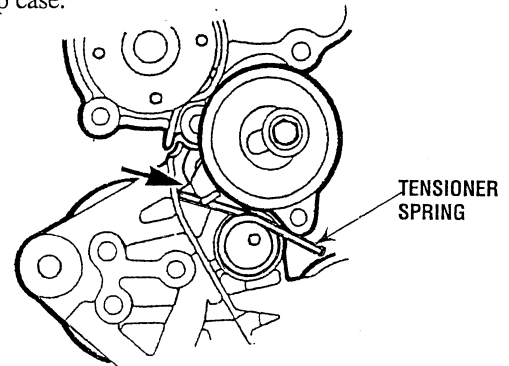

3. Grip the other tensioner spring projection and fit it onto the oil pump case lug as shown in the illustration. Move the timing belt tensioner in the direction shown and temporarily tighten the bolt.

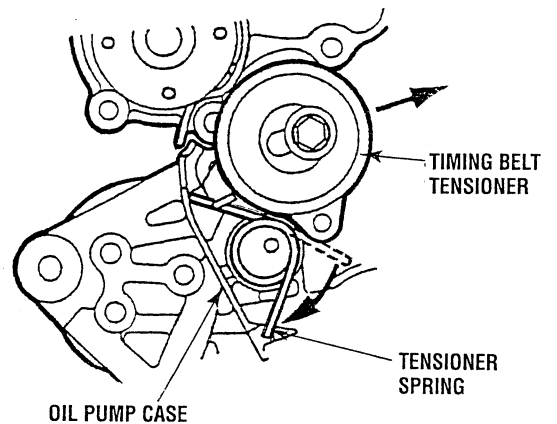

Sprocket Bolt Installation (Camshaft)

Using the special tools shown in the illustration, lock the camshaft sprocket in position and tighten the camshaft sprocket bolt to the specified torque.

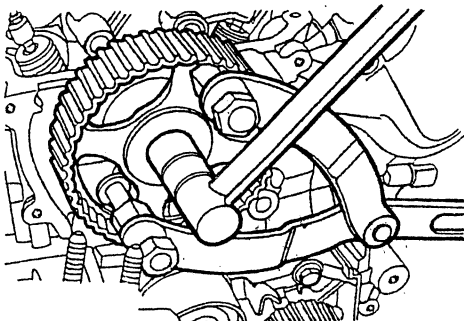

LOCKING THE CAMSHAFT SPROCKET

ENGINE ADJUSTMENTS

NOTE: WESTERBEKE recommends that the following engine adjustments be performed by a competent engine mechanic. The information below is provided to assist the mechanic.

Timing Belt Installation

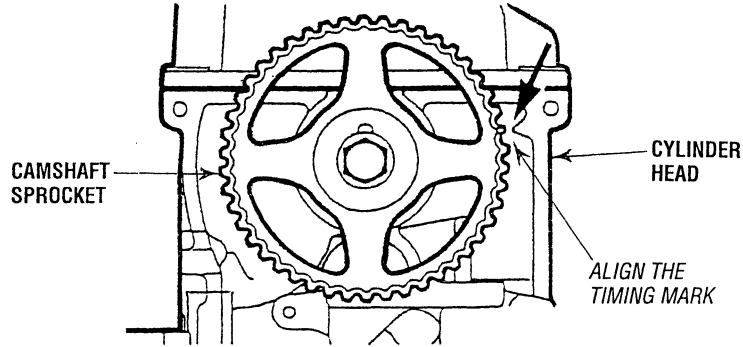

1. Align the camshaft timing mark with the timing mark on the cylinder head.

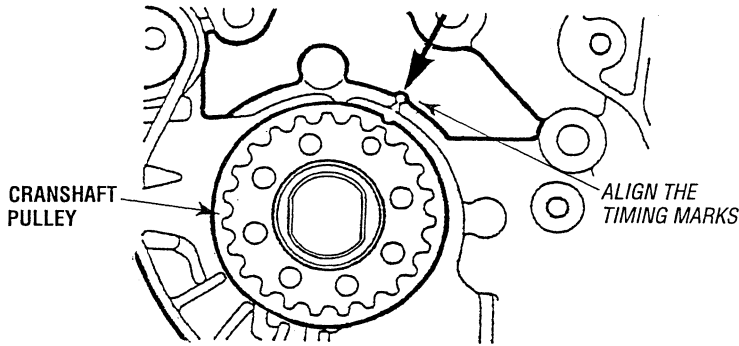

2. Align the crankshaft timing mark with the timing mark on the front case.
3. Keeping the tension side of the timing belt tight, fit the timing belt onto the crankshaft sprocket, camshaft sprocket, and tensioner pulley in that order.
4. Loosen the tensioner pulley mounting bolts by 1/4 to 1/2 of a turn and allow the tensioner spring to apply tension to the timing belt.

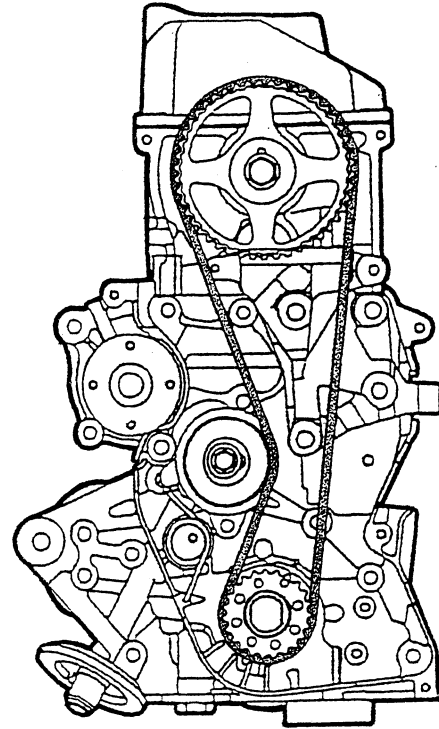

5. Turn the crankshaft twice in the normal rotating direction (clockwise) and check that the timing marks are correctly aligned.

CAUTION: This procedure utilizes the camshaft's driving torque to apply tension evenly to the timing belt. Be sure to turn the crankshaft as described above. Do not turn the crankshaft in reverse.

6. Tighten the tensioner pulley mounting bolts.
IDLER PULLEY BOLTS TORQUE 23 Nm (17 ft-lb)
7. Replace the timing belt covers.
TIMING BELT COVER BOLTS TORQUE 11 Nm (8 ft-lb)

ENGINE TROUBLESHOOTING

The following troubleshooting tables are based upon certain engine problem indicators and the most likely causes of the problems.

When troubleshooting indicates an electrical problem, see the *ELECTRICAL SYSTEM WIRING DIAGRAM* as these may reveal other possible causes of the problem which are not listed below.

NOTE: *The engines control system (electrical system) is protected by a 8 Ampere manual fuse located on the control panel. The generator has an AC circuit breaker at the control panel which should be in the off position when performing troubleshooting.*

PROBLEM	PROBABLE CAUSE
Engine does not crank.	<ol style="list-style-type: none"> 1. Battery is low or dead. 2. Loose battery connections. *3. Faulty wire connections. *4. Faulty start switch. *5. Faulty starter solenoid. 6. Raw water filled cylinders. 7. Filters are clogged by contaminated fuel.
Engine cranks but fails to start.	<ol style="list-style-type: none"> 1. Out of fuel. 2. Engine is flooded. 3. Fuel pump inoperative. 4. Worn or faulty spark plugs. 5. High tension wires grounding (wet system). 6. Faulty ignition coil. 7. Faulty distributor. *8. Faulty wire connections. 9. Low engine compression. 10. Air in the fuel system. See <i>BLEEDING THE FUEL SYSTEM</i>
Engine starts, runs but then shuts down.	<ol style="list-style-type: none"> *1. Faulty shutdown switch. (oil pressure, coolant or exhaust temperature). 2. High engine water or exhaust temperature. *3. Dirty fuel/water separator filter. 4. Low oil level in sump. 5. Faulty fuel pump 6. Faulty engine temperature sensor. 7. Air in the fuel system. See <i>BLEEDING THE FUEL SYSTEM</i>

PROBLEM	PROBABLE CAUSE
Engine starts, runs and then shuts down	<ol style="list-style-type: none"> 8. Fuel line restriction. 9. Mechanical check valve at the fuel supply is faulty 10. Throttle plate binding. 11. Faulty wire connection. *12. AC generator overload. 13. High exhaust pressure.
Engine hunts.	<ol style="list-style-type: none"> 1. Low battery voltage. 2. Generator is overloaded. 3. Cracked distributor cap. 4. Faulty high tension wires. 5. Faulty fuel pump. 6. High exhaust back-pressure. 7. Valves are out of adjustment. 8. Dirty fuel filters.
Engine misfires.	<ol style="list-style-type: none"> 1. Poor quality fuel. 2. Incorrect timing. 3. Dirty flame arrester. 4. Cracked distributor cap. 5. Faulty ignition wires. 6. Spark plugs are worn. 7. High exhaust back-pressure. 8. Valve clearances are incorrect.

* Refer to the *ELECTRICAL TROUBLESHOOTING* guide in this manual for detailed testing of these electrical connections.

ENGINE TROUBLESHOOTING

PROBLEM	PROBABLE CAUSE
Engine backfires.	<ol style="list-style-type: none"> 1. Spark plug wires are connected wrong. 2. Incorrect timing. 3. Engine is flooded. 4. Dirty flame arrester. 5. Cracked distributor cap. 6. High exhaust back-pressure.
Engine overheats.	<ol style="list-style-type: none"> 1. Coolant loss. Pressure test cooling system. 2. Faulty raw water pump impeller. 3. Belts are loose or broken. 4. Raw water pump worn. 5. Faulty thermostat.
Low oil pressure.	<ol style="list-style-type: none"> 1. Low oil level. 2. Wrong SAE type oil in the engine. 3. Faulty or wrong type oil filter. 4. Relief valve is stuck. 5. Faulty oil pump. 6. Faulty engine bearings. 7. Faulty oil filter.
High oil pressure.	<ol style="list-style-type: none"> 1. Dirty oil or wrong SAE type oil in the engine. 2. Relief valve is stuck.

PROBLEM	PROBABLE CAUSE
No DC charge to the starting battery.	<ol style="list-style-type: none"> 1. Faulty connections to battery charging control. 2. Faulty battery charging control. 3. Faulty bridge rectifier. 4. Faulty generator charger windings.
Blue exhaust smoke discharged from the engine.	<ol style="list-style-type: none"> 1. Lube oil is diluted. 2. High lube oil level. 3. Crankcase breather hose is clogged. 4. Valves are worn or adjusted incorrectly. 5. Piston rings are worn or unseated.
Black exhaust smoke discharged from the engine.	<ol style="list-style-type: none"> 1. Dirty flame arrester. 2. Valves are worn or incorrectly adjusted. 3. Lube oil is diluted. 4. Piston rings are worn or unseated. 5. Crankcase breather hose is clogged.
Poor performance at generator speed	<ol style="list-style-type: none"> 1. Main jet clogged. Remove and clean. 2. Fuel pump clogged. Remove and replace. 3. Throttle body filter screen dirty. Remove and clean.

ELECTRICAL TROUBLESHOOTING GUIDE

The following test procedures will require the use of a multimeter and the engine's wiring diagram (in this manual). Also refer to the relay testing page. WESTERBEKE recommends that these tests be performed by a qualified technician.

PROBLEM	TESTING (12 VDC is battery + voltage measured to ground)	INSPECTION/SOLUTION
Engine does not crank.....	Test for B+ (12v) at the circuit breaker to the PC board terminal T4. If OK ↓	Check for bad connections at the engine harness connector P1, the red wire, or at the battery + on the starter. Check the connections at the PC board terminal 4 and at the circuit breaker.
	Test for B+ (12v) at the circuit breaker to the panel fuse end and to the PC board terminal T2. If OK ↓	Look for a bad connection from the circuit breaker to the fuse or at the PC board terminal T2. Replace the circuit breaker.
	Test for B+(12v) from the fuse end to the PC board terminal T1. If OK ↓	Inspect the connections at the fuse or PC board terminal T1. Replace the fuse.
	Test for B+(12v) at the relay K1 terminal 30. If OK ↓	Check for a bad connection at the engine harness connector P1, pin 3. The red/white wire or at K1, K2, terminal 30.
	Test for B+ (12v) at the start/stop switch terminals 2 and 10. If OK ↓	Look for bad connections at the panel connector S2, pin 1, white/black/red wire to the terminal PC board or at the start/stop switch terminals 2 and 10.
	Test for B+ (12v) at the start switch terminal 1 when the switch is activated. If OK ↓	Replace the start switch.
	Test for B+ (12v) at relay K1, terminal 86. If OK ↓	Check for bad connections at the panel connector S2, pin 3, green wire to the PC board. Then check the engine harness connection at the connector P1, pin 7-grey wire. Inspect connections on jumpers on the terminal strip TS1 or between any external contacts connected to TS1. Replace the PC board.
	If OK ↓	
	Test for B+(12v) at relay K1 terminal 85. Activate the start switch and after a few seconds the voltage should drop below .5 volts. If OK ↓	Inspect for a bad connection at relay K1 terminal 8 orange wire or at ECU connector P2, pin2. Replace the ECU
	Activate the start switch, after 4-5 seconds B+(12v) should be present at terminal 87 on relay K1. If OK ↓	Look for a bad connection at relay K1.
	Activate the start switch, after 4-5 seconds check for B+(12v) at the start solenoid. If OK ↓	Look for a bad connection at relay K1, terminal 85 orange wire or at the ECU connector P2 pin. Replace the ECU.
	Inspect the starter.	Check the connections at relay K1 terminal 87. yellow/red wire or at the start solenoid. Replace the starter.

ELECTRICAL TROUBLESHOOTING CHART

The following test procedures will require the use of a multimeter and the engine's wiring diagram (in this manual). Also refer to the relay testing page. WESTERBEKE recommends that these tests be performed by a qualified technician.

PROBLEM	TESTING (12 VDC is battery + voltage measured to ground)	INSPECTION/SOLUTION
Engine cranks but fails to start...	<p>Test for B+ (12v) at terminals 30 and 86 on the K2 run relay If OK ↓</p> <p>Test for B+ (12v) at run relay K2, terminal 85 and activate the start switch. Voltage should be less than 5 volts. If OK ↓</p> <p>Activate the start switch, test for B+(12v) at relay K2 run relay, terminal 87.</p> <p>NOTE: For other possible causes (failure to start) such as fuel pump, speed sensor (MPU), ignition, etc, refer to the these sections in this manual.</p>	<p>Check for bad connections at both terminals. Replace the K2 relay.</p> <p>Inspect the connections at relay K2, terminal 85, or at the ECU connector J2, pin 19.</p> <p>Replace the K2 relay.</p>
Engine starts, runs but shuts down.....	<p>Test for voltage across the oil pressure sensor terminals, with the engine running voltage should be less than 1.0 volts. If OK ↓</p> <p>Test for voltage across the exhaust temperature switch, when the engine shuts down, it should read zero (0) volts. If OK ↓</p> <p>The engine temperature sensor maybe faulty. If OK ↓</p> <p>Fireboy suppression circuit maybe faulty.</p>	<p>Faulty oil pressure sensor. Replace sensor/switch.</p> <p>Faulty exhaust temperature switch. Replace switch. Loss of coolant thru exhaust elbow. High exhaust temperature.</p> <p>Test sensor, refer to component testing in this manual.</p> <p>By-pass Fireboy connection at terminal block. Install a jumper between #4 and #3.</p>

IMPORTANT SYSTEM MONITORING SOFTWARE AND DATA LOGGING

Software, at no charge, is available through your area Master Distributor. The Master Distributor for your area can be located on the Westerbeke website at www.westerbeke.com.

An interconnect cable will need to be purchased (pn# 049998) to connect between the ECU (Electronic Control Unit) in the generator's control box and your laptop to be able to use this software.

The software will be a very important tool for monitoring system operation to ensure the system is operating at its optimum. Also for locating any operating issue and for the very important task of Data Logging used to help determine a cause for engine/system malfunction. For the models listed in this manual, the engine **MUST** be running for the software to communicate with the system ECU. When troubleshooting an engine/system malfunction, start data Logging as soon as the engine is started and running. Then view the data being displayed in the various boxes on the PC Interface.

The Data file can be opened in most spreadsheet forms such as Microsoft Excel.

DATA LOGGING (TROUBLESHOOTING AID)

Test procedures for Data Logging with Gasoline Diagnostic Software-PC Interface

DESCRIPTION

The Diagnostic software is a valuable tool in diagnosing engine problems. It should not replace basic trouble shooting techniques or common sense. Some of our products such as the 5.0 and 6.5 SBCG, and 8.0 through 14.0 SBEG, along with non-OBD 20.0 and 22.5 SBEG do not have an *idle mode*. That means that the engine must be running before the PC Interface can begin communicating. Models such as the OBD versions like the 20.0 and 22.5 SBEGA do have an *idle mode* and PC interface can begin communications before the engine is actually running. Once you have determined which type you have the following procedures will help gather valuable information.

Start off by collecting data from the time that the engine is started. If you have a genset that has the *idle mode*, start the PC interface communicating and data logging before you start the engine. If you have an engine that does not have an *idle mode*, start the PC Interface as soon as possible after the engine is running. Let the engine warm up for about 10 to 15 minutes before trying to apply an AC load. Monitor and record AC volts and amps if possible.

After the engine is warmed up, start applying an AC load by turning on various devices. Let the unit run at each load change for a couple of minutes so that the unit is stable. Monitor and record AC volts and amps if possible at each load site. Continue to add AC load until the unit is at or near full power rating. Power is determined by multiplying the AC voltage times the AC amperage. This will determine if the unit is overloaded or not.

After loading up the genset, begin to reduce the AC load. Let the unit run at each load site for a couple of minutes to stabilize. Continue to reduce the AC load and monitor voltage and amperage until there is no AC load on the genset. This will give a technician a baseline of what is going on when the engine is running under a controlled load condition.

Finally, after running the controlled baseline test, this might sound strange, but sometimes the customer might know a particular scenario that will cause a problem for the unit. Sometimes we hear customers say that the unit runs fine for awhile and when my air conditioner shuts off something happens. Try repeating the scenario that the customer mentions. Always start by recording data from the start up for at least a couple of minutes with no load on the generator to get a starting point. Then continue to record data until the problem shows up.

If you have a unit with no *idle mode*, and the unit shut down under some kind of fault, the data log will automatically stop and save the file. If you have a unit with an *idle mode*, and the unit was to shut down under some kind of fault, you will have to manually stop the data log to save it. Or in the case of shutting of the DC circuit breaker, this will also cause the data log to stop and save itself.

USING THE DATA

All of the data that is being recorded is also being displayed on the PC Interface in the various boxes. The following information applies whether you are looking at the data file after it has been recorded or watching it live in the PC Interface. The data file can be opened in most spreadsheet software such as Microsoft Excel.

Some of the data that is being collected is pretty much self explanatory and simple to follow. For example, I think that engine temp, air temp, oil pressure, and battery volts would be easy to figure out. Some of the other items may be less familiar.

Speed

Simple enough, this is the speed that the engine is running. If the genset is set up to operate at 60 Hz, then the engine needs to run at 1800 rpm (belt driven units may be different). If the unit is setup for 50 Hz operation than the engine speed will be 1500 rpm.

DATA LOGGING (TROUBLESHOOTING AID)

When a genset is governing properly you should see reading slightly above and below the desired speed. Even a well tuned engine will vary a little. The point is you should see readings above and below the desired speed. If you see speed readings remain more than 20 rpm above or below the desired speed for a prolonged period of time, there could be a problem, especially if this is noticed with no AC load applied.

If the speed is too high with no AC load applied check the data box labeled Stepper Pos. (steps). The throttle is controlled by a stepper motor. Usually the step count for engine running with no AC load is typically in the 20 -30 steps range. A couple of steps above or below this range does not indicate a problem. However, if the step count is in the single digit numbers or even showing a zero, the problem maybe that the throttle body assembly may be out of calibration on not functioning properly. The stepper motor can only go to a position that it thinks is zero. If the calibration is off, the stepper cannot move the throttle closed enough to slow the engine down. An engine that has this problem will run at the proper speed once some AC load is added. However, when that load is dropped, the speed will be too high, and in some cases may cause the engine to over-speed and shut down.

If the engine speed is too low with no AC load applied, there is probably a totally different problem. Again, look at the Stepper Position. Is the speed low but steps are high? This would mean that the throttle is being opened to compensate for loss of speed but the speed is not coming up. Check to make sure that the fuel level is full in the fuel system and that the fuel is good and the filters are clear. Check to make sure that the air intake screens are clean. Check to make sure that the spark plugs are not fouled out (*bleed the fuel system looking for air*).

If the engine speed is okay when running with no AC load, but once underway with some AC load being applied the speed drops and stays below the desired speed, first check the AC power by multiplying the total AC amperage times the AC volts to get the kilowatts. If this number is higher than what the unit is rated for, then it is overloaded. Shut off some of the devices until the speed returns to normal and check the power again. If there is only a small AC load applied and the speed cannot maintain, follow the same suggestions from the previous paragraph.

Pressure (kPa)

This is the pressure that exists in the intake manifold. At no load the kPa will be lower than at full load. The wider the throttle plate is opened the closer it gets to atmosphere which is about 100 kPa. Typically a genset running at no load will see a kPa value around 30, while at full load it would be around 90 kPa. If the kPa is stuck at 70 and never moves than there is a problem with either the MAP sensor or the wiring to the MAP sensor, as 70 is a default value that is in the code.

WB Heater Set-point

This is the set-point in millivolts of the heater temperature in the Wideband O2 Sensor. Currently in all the units that do not have an *idle mode*, the set-point is 893. In other units the set-point will vary, but will be displayed in this box.

WB Current Temp

This is the actual value in millivolts of the heater temperature in the Wideband O2 Sensor. If the heater is working properly, you will typically see values stay within 20 millivolts of the set-point. The higher the number is, the colder the heater is. Typically a reading in the 4000 area means that the heater is not working at all. If the value is swinging dramatically above and below the set-point the sensor is probably failing. The sensor should be replaced.

DATA LOGGING (TROUBLESHOOTING AID)

Lambda

Lambda represents the ratio of the amount of oxygen actually present in a combustion chamber compared to the amount that should have been present in order to obtain "perfect" combustion. Thus, when a mixture contains exactly the amount of oxygen required to burn the amount of fuel present, the ratio will be one to one and lambda will equal 1.000. If the mixture contains too much oxygen for the amount of fuel (a lean mixture), lambda will be greater than 1.000. If a mixture contains too little oxygen for the amount of fuel (a rich mixture), lambda will be less than 1.000.

We all know that perfect combustion requires an air/fuel ratio of approximately 14.7:1 (by weight) under normal conditions. Thus a lean air/fuel ratio of, say, 16:1 would translate to a lambda value of 1.088. (To calculate, divide 16 by 14.7.) A lambda of .97 would indicate an air/fuel ratio of 14.259:1 (derived by multiplying .97 by 14.7).

In our applications we want to see a lambda reading around 1.000. Because of the combustion involved this number will constantly be changing, ideally you should see the value for lambda fluctuating slightly above and below the 1.000 target.

Immediately after a startup it is typical to see rich readings for lambda. This is part of the startup process and usually takes a couple of minutes for sensors to warm up and take control of the air fuel mixture.

If you see a problem in this area first check the Wideband heater values to make sure that the heater is working. Remember that it takes about three minutes after starting an engine for it to be totally in control. Physically remove the sensor and check it for corrosion or build up of deposits from the water being injected through the exhaust. Salt water deposited on the sensor will be very damaging. If there is any evidence of build up, replace the sensor.

After checking the sensor and the genset is running too rich, check the air intake screens and spark plugs to make sure they are clean and functioning properly. If the genset is running too lean, check the fuel levels and the quality of the fuel. Water in the gas is no good and will cause the genset to run lean.

Ip Current

This is the electrical value equivalent of the Lambda reading. There is not much to learn from this number.

Lambda PW Trim

This is the fueling trim percentage that the wideband oxygen sensor is contributing. In most cases 15% is the maximum.

Wideband P, I & D Term

These values are the Wideband Sensor Heater temperature control terms. These values will be constantly changing. It is more important to look at the WB Current Temp value.

Lambda P & I Term

These values are the lambda value controlling terms. Their job is to keep the lambda reading at 1.000 by enriching or enleaning the fueling.

NB STT

(Narrowband Short Term Trim) If your genset is equipped with a narrowband oxygen sensor, this will be the value of its contribution. Max contribution is 1%.

DATA LOGGING (TROUBLESHOOTING AID)

Stepper Pos (steps)

The throttle shaft is controlled by a stepper motor. The value displayed is in steps. Zero steps being the closed position. Most units will run at no load in the 20 to 30 steps range. These values will vary from engine to engine.

Pulse Width

This is the fueling duration in milliseconds (ms). The value will be lower at no load than at full load.

Main Fuel Comp (%)

This is the fueling compensation that is derived from a value in the fuel table, which is based on the engine rpm and the MAP pressure.

Air Temp and Engine Temp Comp (%)

This is the fueling compensation based on the air temperature and engine temperature. This value can be both positive and negative. This value is added or subtracted from the Main Fuel Compensation value.

Speed P, I & D Terms

These values reflect the engine speed governing process. These values are constantly changing and it is very hard to get any information from them. The only thing I can say on the subject is that you should see these values constantly changing. If for some reason there are all zeroes in these columns than the engines is probably not running.

De-rated P Term

The code provides for the P (Proportional) Term, in the Speed PID control, to be de-rated right after start-up for a short period of time. This allows the engine to warm up with out having an aggressive P value which could cause "hunting" or instability when the engine is cold. On some older units there is also a trim pot on the top on the ECU that can manually de-rate the P value. This will be reflected in this box.

Frequency Option

This is the value of the speed selector on the ECU, whether it is 50 or 60 Hz. Some interfaces may not show this column but will display the Frequency Option in the Title area at the top on the data log.

Gen. Frequency

The Generator Frequency is a function of engine speed. For most applications, 50 Hz operation is with an engine speed of 1500 rpm, while 60 Hz operation is with an engine speed of 1800 rpm. Note: Belt drive applications will be different, check your owner's manual for engine speed.

DC ELECTRICAL SYSTEM

ALTERNATOR

The charging system consists of a DC belt driven alternator with a voltage regulator, an engine DC wiring harness, a mounted DC circuit breaker and a battery with connecting cables. Because of the use of integrated circuits (IC's), the electronic voltage regulator is very compact and is mounted internally or on the back of the alternator.

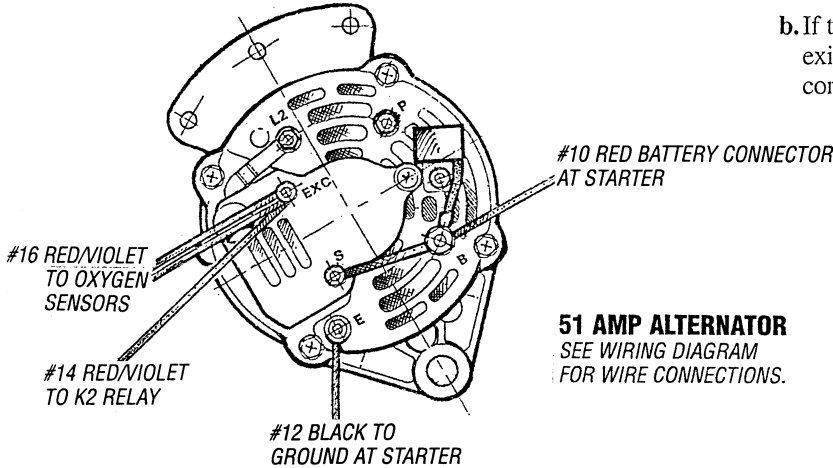

ALTERNATOR TROUBLESHOOTING

WARNING: A failed alternator can become very hot. Do not touch until the alternator has cooled down.

Use this troubleshooting section to determine if a problem exists with the charging circuit or with the alternator. If it is determined that the alternator or voltage regulator is faulty, have a qualified technician check it.

The alternator charging circuit charges the starting battery and the service battery. An isolator with a diode, a solenoid or a battery selector switch is usually mounted in the circuit to isolate the batteries so the starting battery is not discharged along with the service battery. If the alternator is charging the starting battery but not the service battery, the problem is in the service battery's charging circuit and not with the alternator.

Testing the Alternator

CAUTION: Before starting the engine make certain that everyone is clear of moving parts! Keep away from sheaves and belts during test procedures.

WARNING: When testing with a multimeter: DC and AC circuits are often mixed together in marine applications. Always disconnect a shore power cord, isolate DC and AC converters, and shut down the engine before performing DC testing. No AC tests should be made without a proper knowledge of AC circuits.

1. Start the engine.
2. After the engine has run for a few minutes, measure the starting battery voltage at the battery terminals using a multimeter set on DC volts.
 - a. If the voltage is increasing toward 14 volts, the alternator is working; omit Steps 3 through 8 and go directly to "Checking the Service Battery" on the next page.
 - b. If the voltage remains around 12 volts, a problem exists with either the alternator or the charging circuit; continue with Steps 3 through 8.

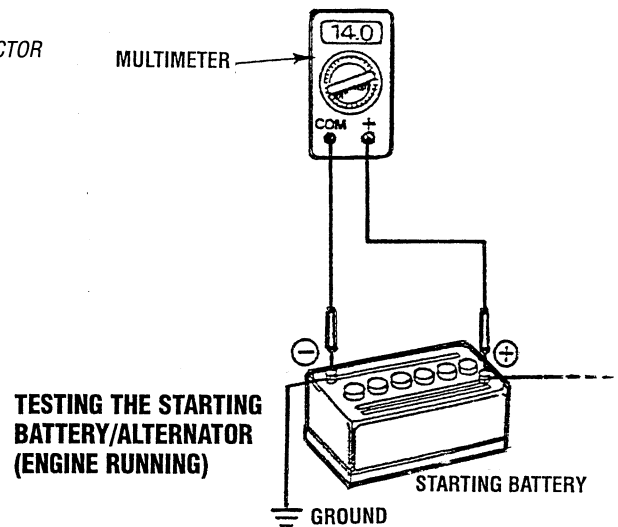

TESTING THE STARTING BATTERY/ALTERNATOR (ENGINE RUNNING)

3. Turn off the engine. Inspect all wiring and connections. Ensure that the battery terminals and the engine ground connections are tight and clean.

CAUTION: To avoid damage to the battery charging circuit, never shut off the engine battery switch when the engine is running!

4. If a battery selector switch is in the charging circuit, ensure that it is on the correct setting.
5. Turn on the ignition switch, but do not start the engine.
6. Check the battery voltage. If the battery is in good condition, the reading should be 12 to 13 volts.

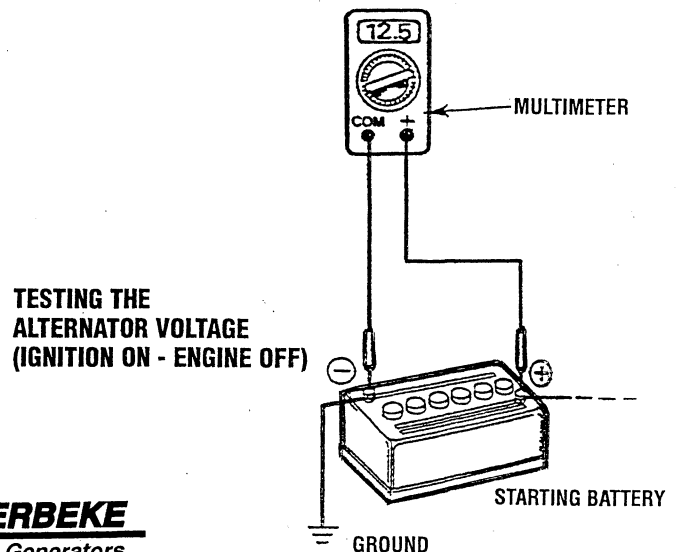

TESTING THE ALTERNATOR VOLTAGE (IGNITION ON - ENGINE OFF)

DC ELECTRICAL SYSTEM

7. Now check the voltage between the alternator output terminal (B+) and ground. If the circuit is good, the voltage at the alternator will be the same as the battery, or if an isolator is in the circuit the alternator voltage will be zero. If neither of the above is true, a problem exists in the circuit between the alternator and the battery. Check all the connections — look for an opening in the charging circuit.

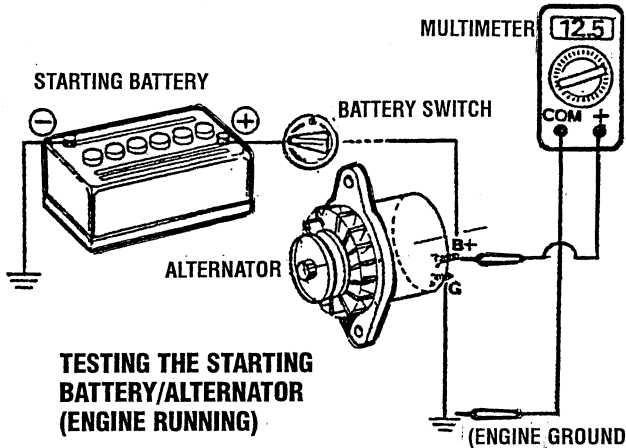

8. Start the engine again. Check the voltage between the alternator output and ground. The voltage reading for a properly operating alternator should be between 13.5 and 14.5 volts. If your alternator is over- or under-charging, have it repaired at a reliable service facility.

NOTE: Before removing the alternator for repair, use a voltmeter to ensure that 12 volts DC excitation is present at the EXC terminal if the previous test showed only battery voltage at the B output terminal.

If 12 volts is not present at the EXC terminal, trace the wiring and look for breaks and poor connections.

12 VOLT DC CONTROL CIRCUIT

The engine has a 12 volt DC electrical control circuit that is shown on the wiring diagrams that follow. Refer to these diagrams when troubleshooting or when servicing the DC electrical system.

CAUTION: To avoid damage to the battery charging circuit, never shut off the engine battery switch while the engine is running. Shut off the engine battery switch, however, to avoid electrical shorts when working on the engine's electrical circuit.

BATTERY

The recommended "dedicated" battery used for the engine's starting 12 volt DC control circuit should be 800-1000 Cold Cranking Amps (CCA) rated.

Checking the Service Battery

Check the voltage of the service battery. This battery should have a voltage between 13 and 14 volts when the engine is running. If not, there is a problem in the service battery charging circuit. Troubleshoot the service battery charging circuit by checking the wiring and connections, the solenoid, isolator, battery switch, and the battery itself.

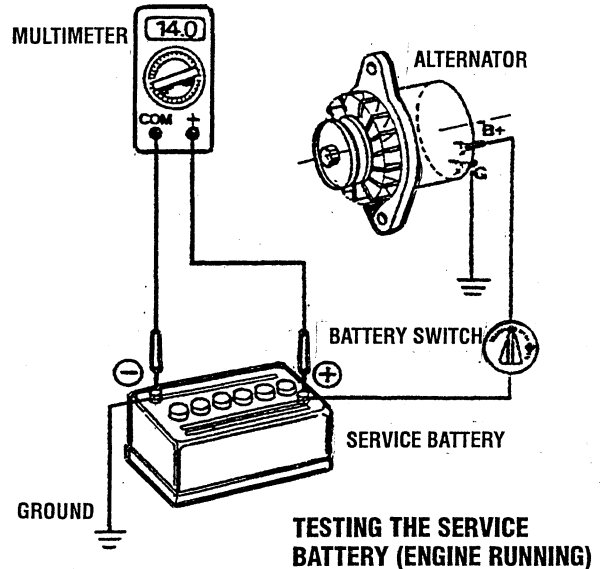

CAUTION: To avoid damaging the alternator diodes, do not use a high voltage tester (i.e. a megger) when performing tests on the alternator charging circuit.

Battery Care

Review the manufacturer's recommendations and then establish a systematic maintenance schedule for your engine's starting batteries and house batteries.

- Monitor your voltmeter for proper charging during engine operation.
- Check the electrolyte level and specific gravity with a hydrometer.
- Use only distilled water to bring electrolytes to a proper level.
- Make certain that battery cable connections are clean and tight to the battery posts (and to your engine).
- Keep your batteries clean and free of corrosion.

WARNING: Sulfuric acid in lead batteries can cause severe burns on skin and damage clothing. Wear protective gear.

WIRING SCHEMATIC #49167

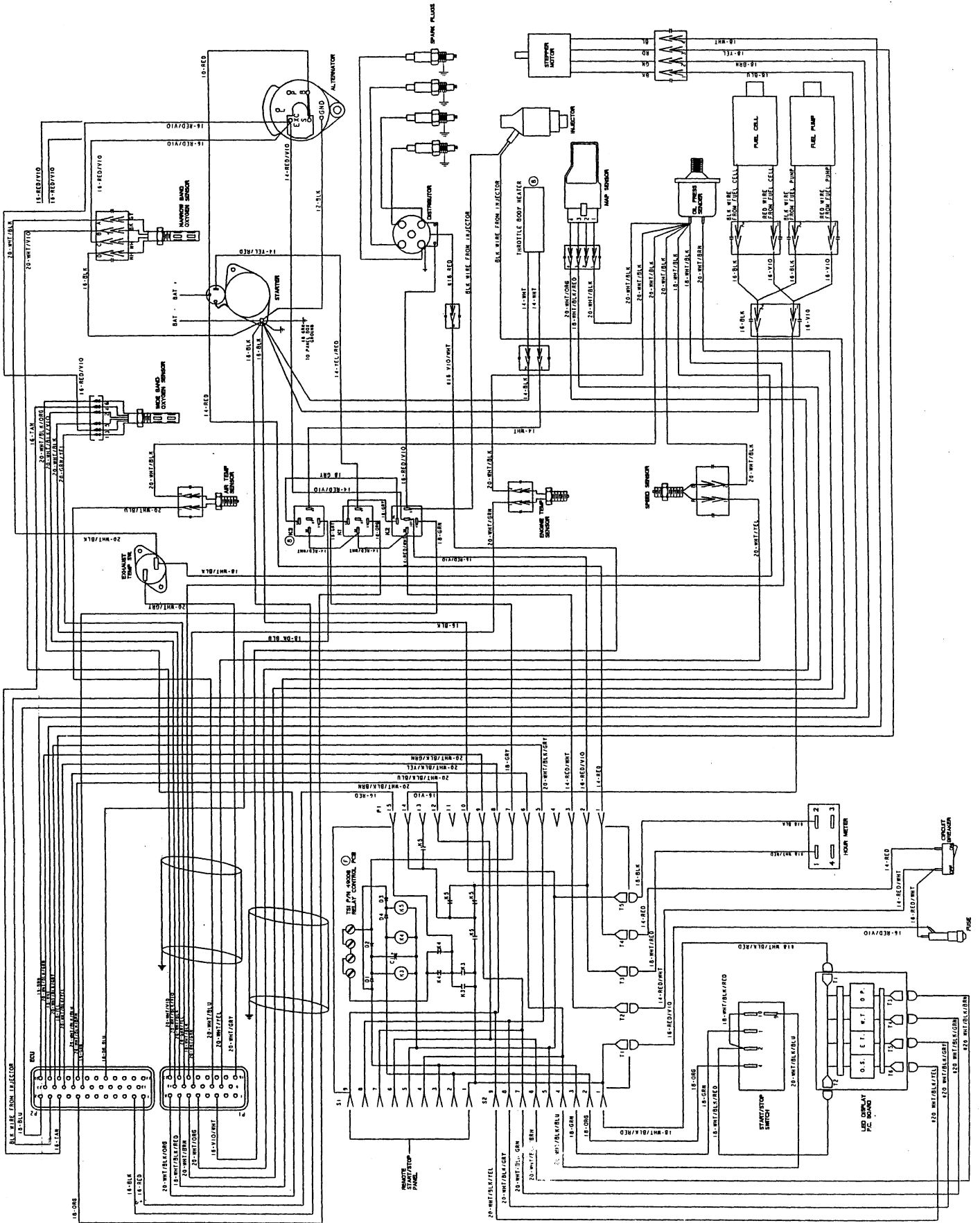

REMOTE STOP/START PANEL WIRING DIAGRAM DISPLAY BOARD SCHEMATIC

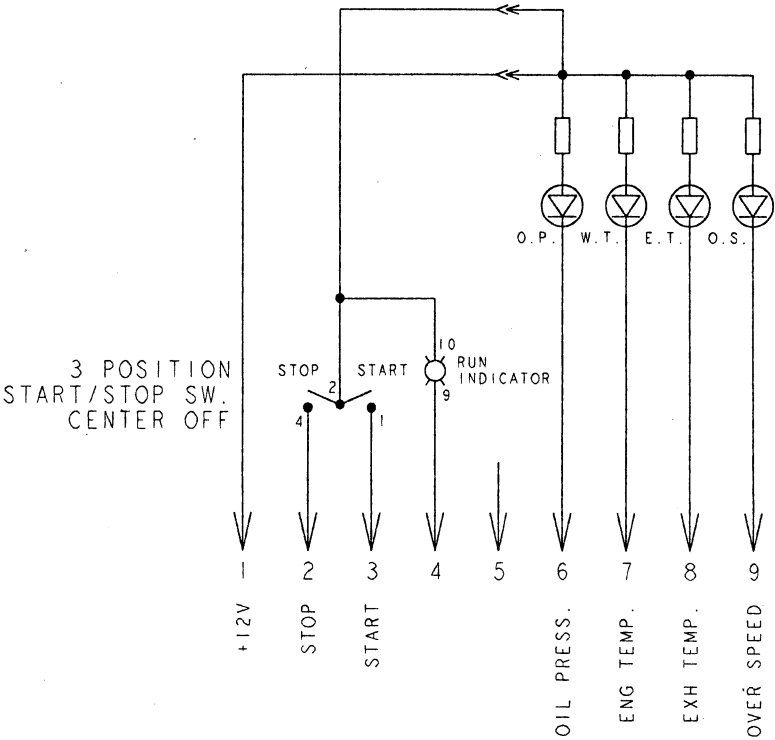
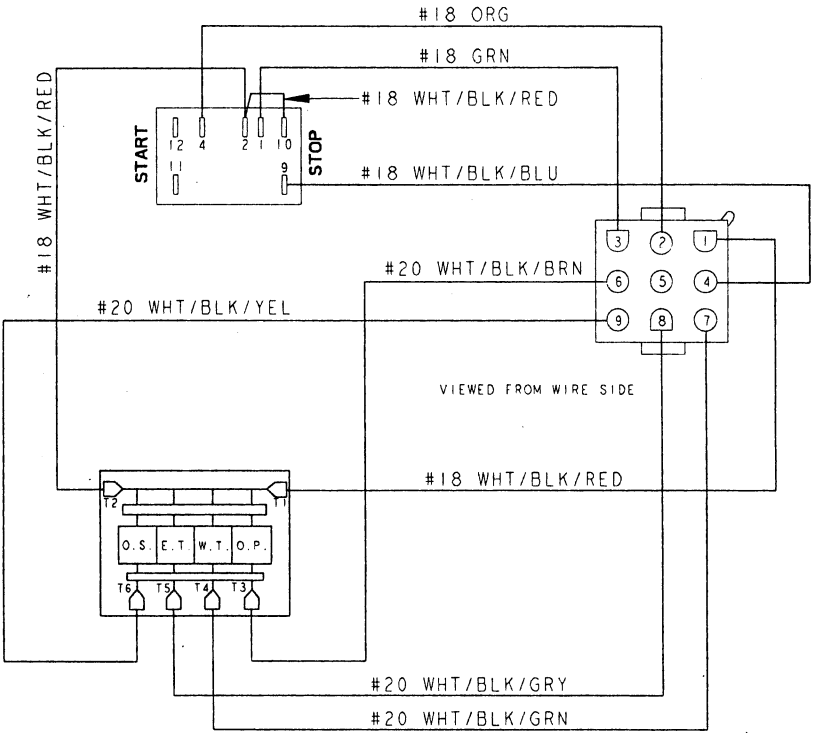

STARTER MOTOR

DESCRIPTION

The *starter* can be roughly divided into the following sections:

- A motor section which generates a drive power.
- An overrunning clutch section which transmits an armature torque, preventing motor overrun after starting.
- A switch section (solenoid) which is operated when actuating the overrunning clutch through a lever and which supplies load current to the motor.

The starter is a new type, small, light-weight and is called a high-speed internal-reduction starter. The pinion shaft is separate from the motor shaft; the pinion slides only on the pinion shaft. A reduction gear is installed between the motor shaft and a pinion shaft. The pinion sliding part is not exposed outside the starter so that the pinion may slide smoothly without becoming fouled with dust and grease. The motor shaft is supported at both ends on ball bearings. The lever mechanism, switch and overrunning clutch inner circuit are identical to conventional ones.

ADJUSTMENT AND REPAIR

If any abnormality is found by the following tests, the starter should be disassembled and repaired.

Pinion Gap Inspection

1. Connect a battery (12V) between the starter terminal S and the starter body, and the pinion drive should rotate out and stop.

CAUTION: Never apply battery voltage for over 10 seconds continuously.

2. Lightly push the pinion back and measure the return stroke (called pinion gap).
3. If the pinion gap is not within the standard range, (0.5 to 2.0 mm), adjust it by increasing or decreasing the number of shims on the solenoid. The gap is decreased as the number of shims increases.

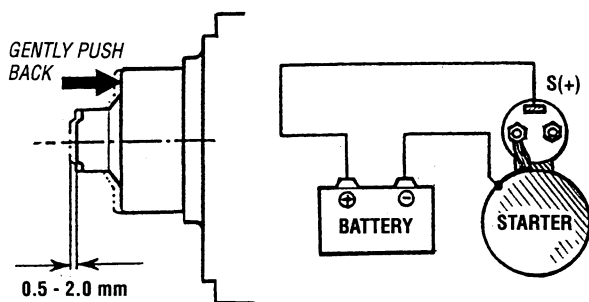

PINION GAP

No-Load Test

1. Connect the ammeter, voltmeter, and battery to the starter as illustrated.
2. When the switch is closed, the pinion must protrude and the starter must run smoothly (at 3000 rpm or more). If the current or starter speed is out of specification, disassemble the starter and repair it.

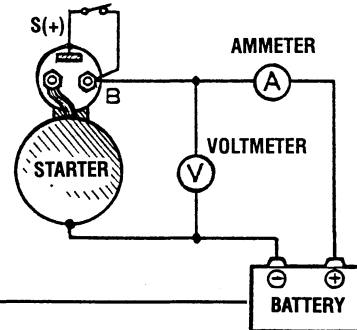

CAUTION: Use thick wires as much as possible and tighten every terminal securely. This is a solenoid shift-type starter which makes a rotating sound louder than that of a direct-drive type starter. When detecting starter rotation at the pinion tip, be careful not to come in contact with the pinion gear when it protrudes.

SOLENOID

Perform the following tests. If any test result is not satisfactory, replace the solenoid assembly.

1. Inspect the solenoid for continuity between terminals (+) and (-) and between terminals S and the body and M and the body. There should be no continuity found between terminals S and M. Continuity will be found between terminals S and the body and terminal M and the body.

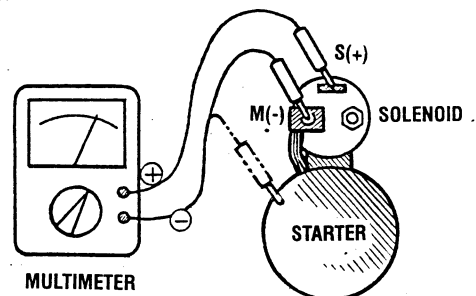

NOTE: Disconnect the wire from terminal M.

2. Connect a battery to the solenoid's terminal S for (+) and M for (-). Have a switch in the + lead and close it. The pinion drive should extend fully out.

CAUTION: Do not apply battery current for more than 10 seconds when testing the solenoid.

STARTER MOTOR

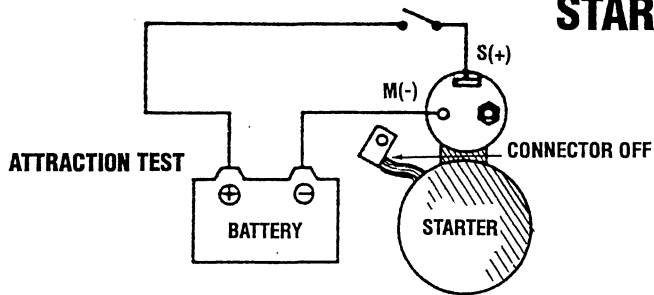

3. *Holding test.* With a battery connected to the solenoid terminal S (+) and to the starter body, manually pull out the pinion fully. The pinion must remain at that position even when released from holding with your hand.

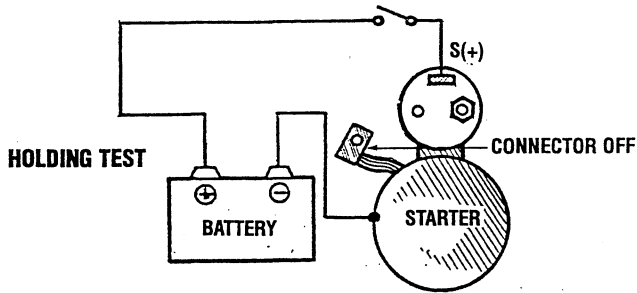

4. *Return test:* With a battery connected to the solenoid terminal M (-) and to the starter body, manually pull out the pinion fully. The pinion must return to its original position when released from holding by hand.

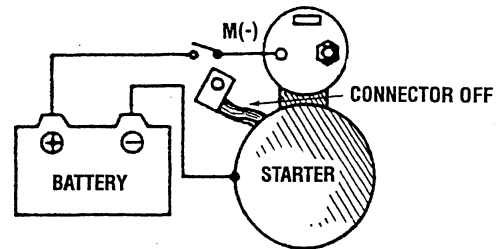

STARTER DISASSEMBLY

1. Disconnect the wire from the solenoid terminal M (-).
2. Loosen the two screws fastening the solenoid. Remove the solenoid assembly.
3. Remove the two long through bolts and two screws fastening the brush holder. Remove the rear bracket.
4. With the brushes pulled away from the armature, remove the yoke and brush holder assembly. Then pull the armature out.
5. Remove the cover, pry the snap ring out, and remove the washer.
6. Unscrew the bolts and remove the center bracket. At the same time, the washers for the pinion shaft end play adjustment will come off.
7. Pull out the reduction gear lever and lever spring from the front bracket.
8. On the pinion side, pry the snap ring out, and pull out the pinion and pinion shaft.
9. At each end of the armature, remove the ball bearing with a bearing puller. It is impossible to replace the ball bearing press-fitted in the front bracket. If that bearing has worn off, replace the front bracket assembly.

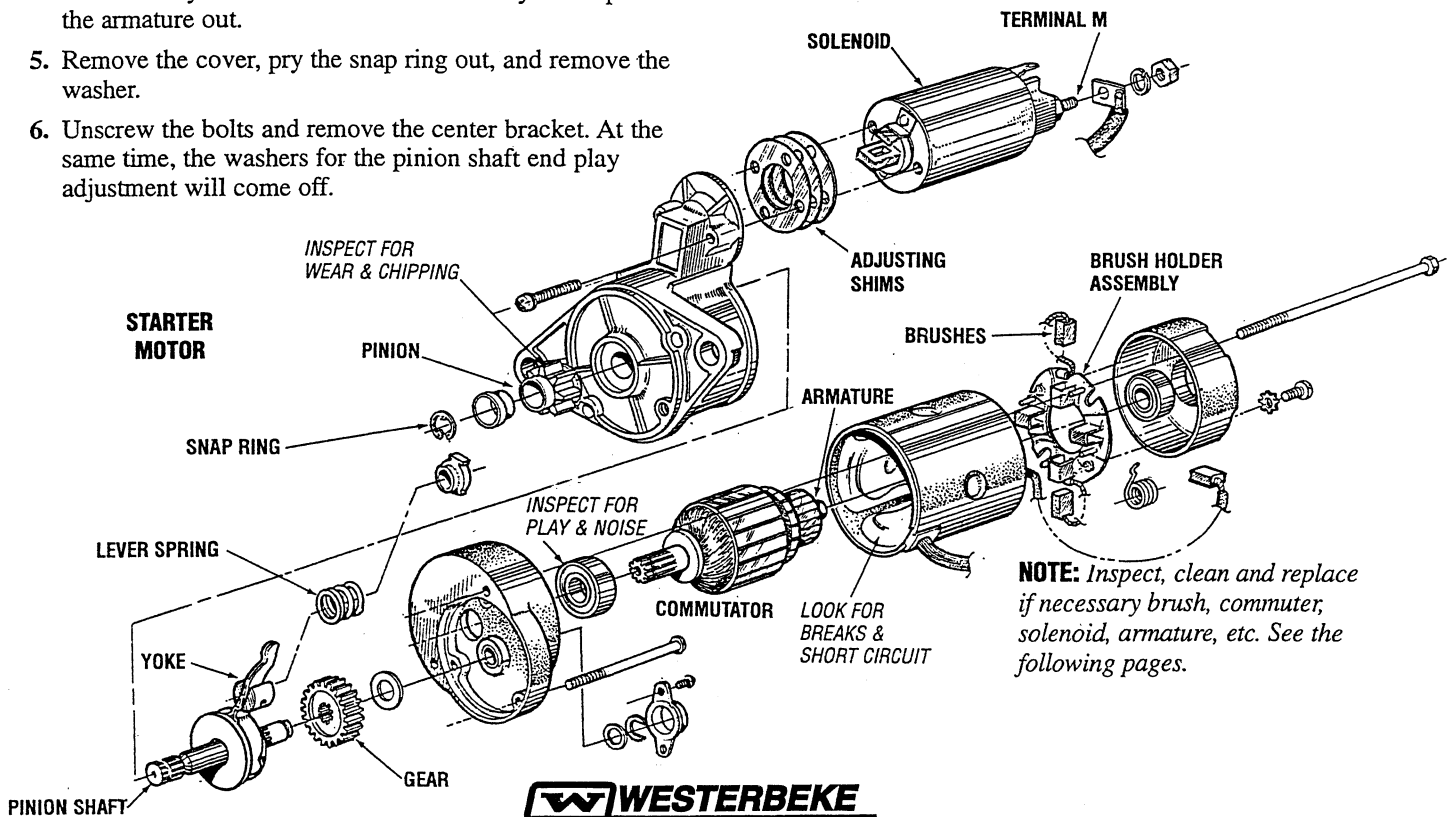

GENERATOR INFORMATION

USE OF ELECTRIC MOTORS

The power required to start an electric motor is considerably more than is required to keep it running after it is started. Some motors require much more current to start them than others. Split-phase (AC) motors require more current to start, under similar circumstances, than other types. They are commonly used on easy-starting loads, such as washing machines, or where loads are applied after the motor is started, such as small power tools. Because they require 5 to 7 times as much current to start as to run, their use should be avoided, whenever possible, if the electric motor is to be driven by a small generator. Capacitor and repulsion-induction motors require from 2 to 4 times as much current to start as to run. The current required to start any motor varies with the load connected to it. An electric motor connected to an air compressor, for example, will require more current than a motor to which no load is connected.

In general, the current required to start 115-Volt motors connected to medium starting loads will be approximately as follows:

MOTOR SIZE (HP)	AMPS FOR RUNNING (AMPERES)	AMPS FOR STARTING (AMPERES)
1/6	3.2	6.4 to 22.4*
1/4	4.6	9.2 to 32.2*
1/3	5.2	10.4 to 72.8*
1/2	7.2	14.4 to 29.2*
3/4	10.2	20.4 to 40.8*
1	13	26 to 52

***NOTE:** In the above table the maximum Amps for Starting is more for some small motors than for larger ones. The reason for this is that the hardest starting types (split-phase) are not made in larger sizes.

Because the heavy surge of current needed for starting motors is required for only an instant, the generator will not be damaged if it can bring the motor up to speed in a few seconds. If difficulty is experienced in starting motors, turn off all other electrical loads and, if possible, reduce the load on the electric motor.

Required Operating Speed

Run the generator first with no load applied, then at half the generator's capacity, and finally loaded to its full capacity as indicated on the generator's data plate. The output voltage should be checked periodically to ensure proper operation of the generating plant and the appliances it supplies. If an AC voltmeter or ampmeter is not installed to monitor voltage and load, check it with a portable meter and amp probe.

NOTE: When the vessel in which the generator is installed contains AC equipment of 120 volts only, it is recommended that the generator's AC terminal block be configured to provide one 120 volt AC hot leg for the vessel's distribution panel. This will ensure good motor starting response from the generator.

Generator Frequency Adjustment

Frequency is a direct result of engine/generator speed, as indicated by the following:

- When the generator is run at 1800 RPM, the AC voltage output frequency is 60 Hertz.

Therefore, to change the generator's frequency, the generator's drive engine's speed must be changed along with a reconfiguring of the AC output connections at the generator.

Generator Maintenance

- Maintaining reasonable cleanliness is important. Connections of terminal boards and rectifiers may become corroded, and insulation surfaces may start conducting if salts, dust, engine exhaust, carbon, etc. are allowed to build up. Clogged ventilation openings may cause excessive heating and reduced life of windings.
- For unusually severe conditions, thin rust-inhibiting petroleum-base coatings, should be sprayed or brushed over all surfaces to reduce rusting and corrosion.
- In addition to periodic cleaning, the generator should be inspected for tightness of all connections, evidence of overheated terminals and loose or damaged wires.
- The drive discs on single bearing generators should be checked periodically if possible for tightness of screws and for any evidence of incipient cracking failure. Discs should not be allowed to become rusty because rust may accelerate cracking. The bolts which fasten the drive disc to the generator shaft must be hardened steel SAE grade 8, identified by 6 radial marks, one at each of the 6 corners of the head.
- The rear armature bearing is lubricated and sealed; no maintenance is required. However, if the bearing becomes noisy or rough-sounding, have it replaced.
- Examine bearing at periodic intervals. No side movement of shaft should be detected when force is applied. If side motion is detectable, inspect the bearing and shaft for wear. Repair must be made quickly or major components will rub and cause major damage to generator.

CIRCUIT BREAKER

A circuit breaker is installed on all WESTERBEKE generators. This circuit breaker will automatically disconnect generator power in case of an electrical overload. The circuit breaker can be manually shut off when servicing the generator to ensure that no power is coming into the boat.

Carbon Monoxide Detector

WESTERBEKE recommends mounting a carbon monoxide detector in the vessel's living quarters. **Carbon Monoxide, even in small amounts, is deadly.**

The presence of carbon monoxide indicates an exhaust leak from the engine or generator or from the exhaust elbow/exhaust hose, or that fumes from a nearby vessel are entering your boat.

AC VOLTAGE REGULATOR (CURRENT MODELS)

#054596

VOLTAGE POTENTIOMETER

The output voltage of the generator can be adjusted using the potentiometer with the generator running at its selected speed (frequency) by turning the adjustment until the desired voltage is obtained. **NOTE:** *If the voltage is set higher than selected rated voltage, the generator may be damaged.*

FREQUENCY

A **jumper** on the regulator is connected to two of the three pins for either 60 hertz or 50 hertz operation. **NOTE:** *This does not automatically change the engine speed. Engine speed change is performed using the adjustment on the belt driven mechanical governor.*

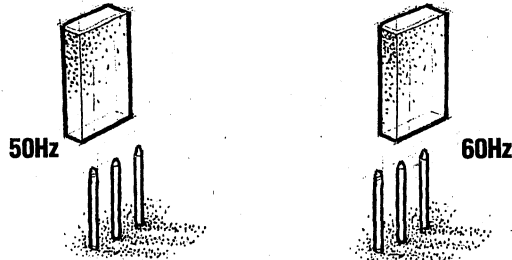

STABILITY

If at no-load or while under load with steady engine speed, AC output voltage fluctuation is experienced. Adjust the **stability** potentiometer. This modulates the reaction time of the regulator to external inputs, thereby eliminating any instability in the AC generator load system.

UNDER FREQUENCY

The **UNDER FREQUENCY** potentiometer on the regulator can not be adjusted in the field. The control ECU is monitoring engine speed and will react to stop the unit should engine speed fall below a preset level. The **UNDER FREQUENCY** circuit in the regulator can be a cause of voltage/light flicker in a new regulator. If this occurs, turn the potentiometer counter clockwise 5-6 turns to arrest this.

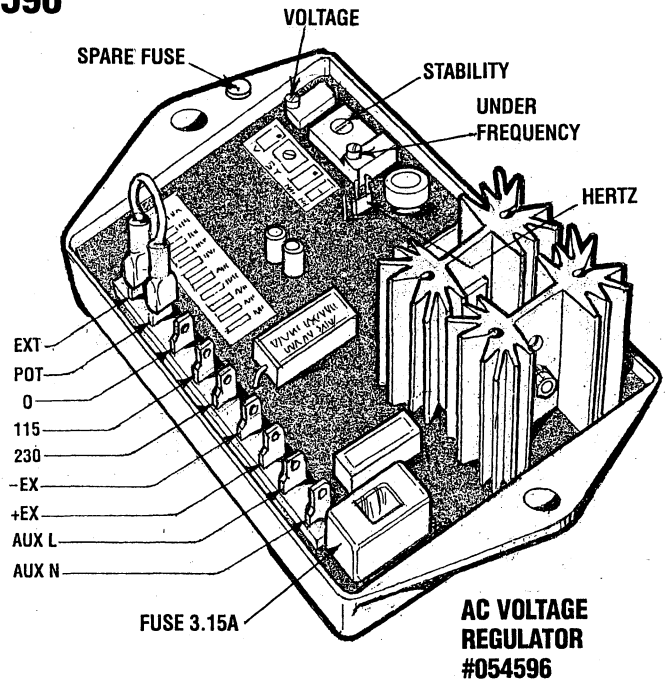

VOLTAGE SENSING

The voltage sensing connections are **0** and **115** when selected output voltage is between **100V** and **140V**. Connect between **0** and **230** when selected output voltage is between **200V** and **280V**.

EXCITER WINDING

Proper polarity in this circuit **must** be maintained. **Black** to **- Ex** and **red** to **+ Ex**. Failure to do so may damage the regulator.

AUXILIARY WINDING

Connect the correct color wires to the terminals. Green or gray to **Aux L** and blue and brown to **Aux N**.

EXCITING THE GENERATOR

Exciting the generator using an external DC source can be performed when troubleshooting a generator/AC voltage output issue.

The following procedure should be followed:

1. The generator should not be operating. Remove the **- Ex** and **+ Ex** electrical connections off the regulator.
2. Maintaining polarity. Connect the **+** (plus) from a **9 volt dry cell** battery to the **+ Ex (red)** electrical lead coming from the generator and the **-** (negative) to the **- Ex (Black)** electrical lead coming from the generator.
3. Start the generator and observe the reaction and voltage output from the generator and react accordingly.

The troubleshooting booklet for the BE style generator will help you determine the cause of a generator AC voltage output issue by the AC voltage found being produced by the generator and the reaction of the generation to excitation.

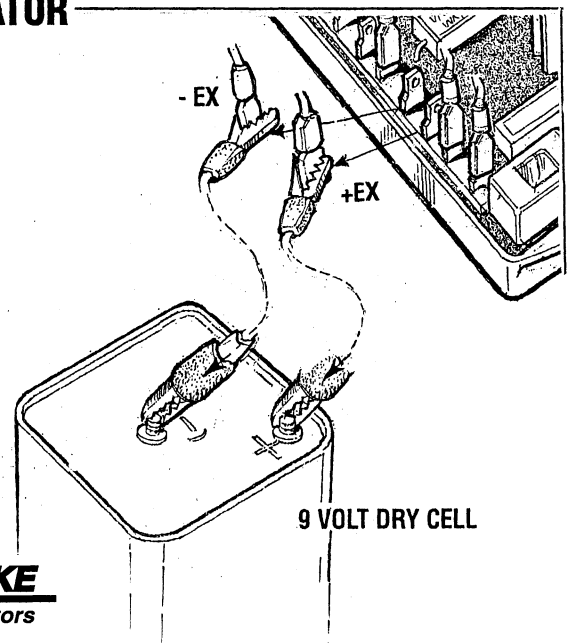

AC VOLTAGE REGULATOR (CURRENT MODELS) #054596

VOLTAGE REGULATOR #054596

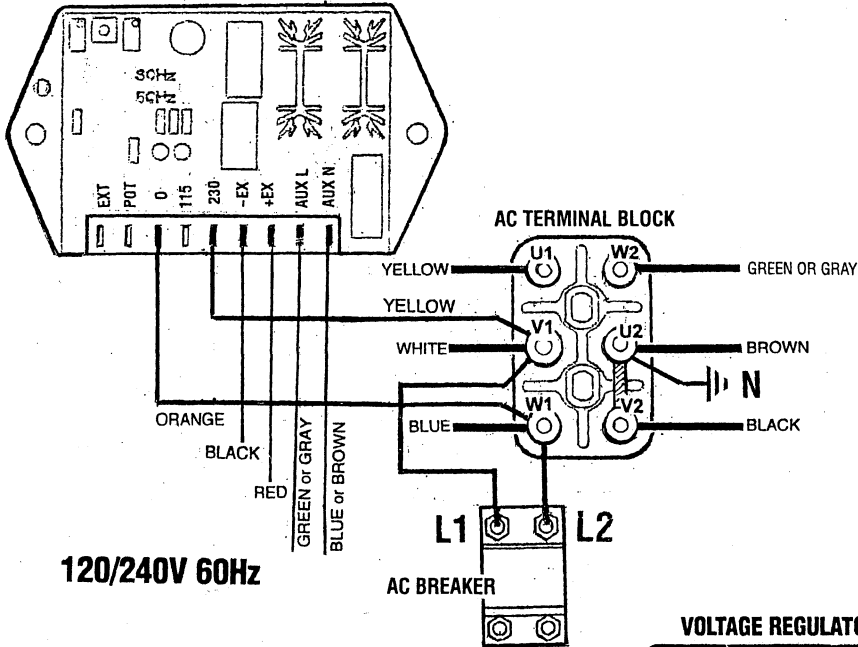

VOLTAGE REGULATOR #054596

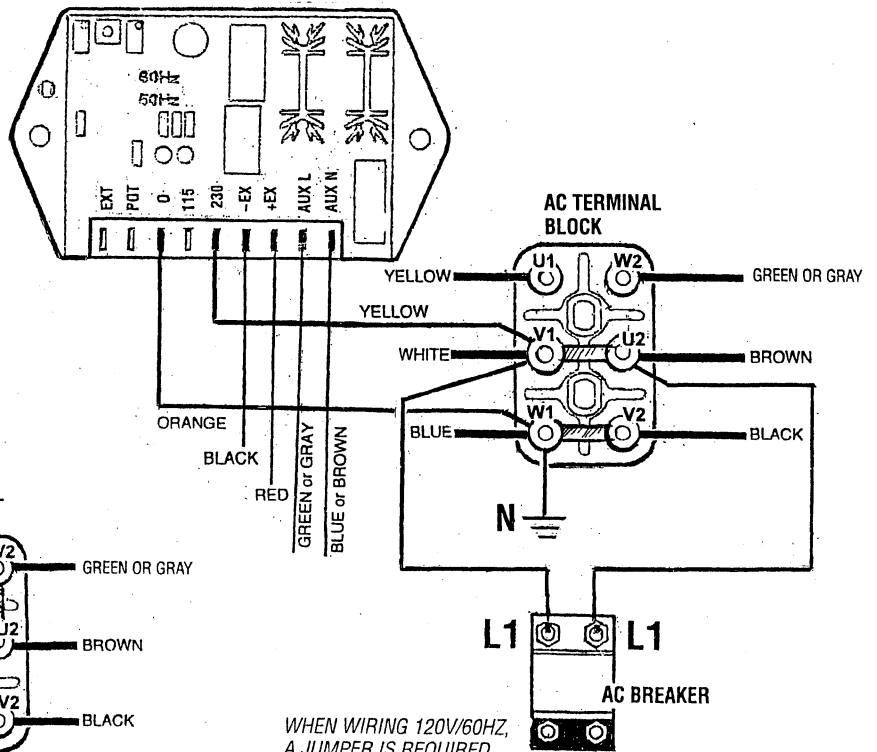

VOLTAGE REGULATOR #054596

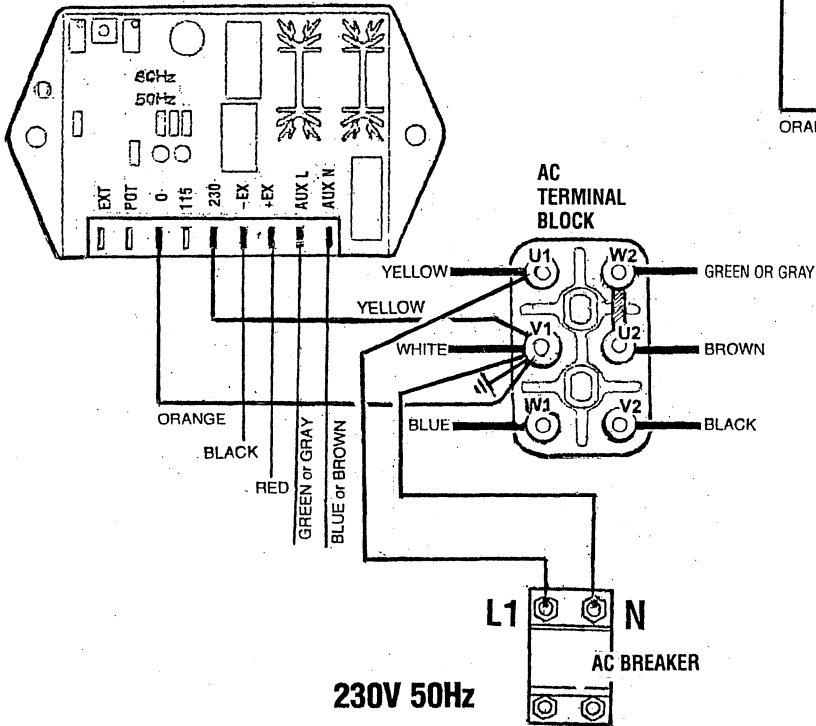

THE BE GENERATOR (EARLY MODELS) WITH VOLTAGE REGULATOR #046446

DESCRIPTION

This generator is a four-pole, brushless, self-excited generator which requires only the driving force of the engine to produce AC output. The copper and laminated iron in the exciter stator are responsible for the self-exciting feature of this generator. The magnetic field produced causes an AC voltage to be induced into the related exciter rotor windings during rotation. Diodes located in the exciter rotor rectify this voltage to DC and supply it to the windings of the rotating field. This creates an electromagnetic field which rotates through the windings of the main stator, inducing an AC voltage which is supplied to a load. An AC voltage is produced in the auxiliary windings of the main stator and is, in turn, supplied to a voltage regulator. The regulator produces a DC voltage to further excite the exciter stator windings, enabling the generator to produce a rated AC output. The voltage regulator senses AC voltage output and adjusts DC excitation to the exciter stator winding according to amperage load the generator is furnishing. To maintain a constant voltage output.

Voltage Adjustments

This potentiometer is used to adjust output voltage. At proper engine operating speed the output voltage should be held at $\pm 2\%$ from a no-load condition to a full rated generator output and from power factor 1.0 with engine drive speed variations up to .5Hz (1%).

With the alternator running at no-load, at normal speed, and with VOLT adjust at minimum, it is possible that output voltage will oscillate. Slowly rotate the VOLT adjustment clockwise. The voltage output of the alternator will increase and stabilize. Increase the voltage to the desired value.

Once the generator has been placed into operation and as break-in is/has taken place. A no-load AC voltage adjustment maybe needed along with a "GAIN" adjustment. See voltage adjustment and ECU adjustments in this manual

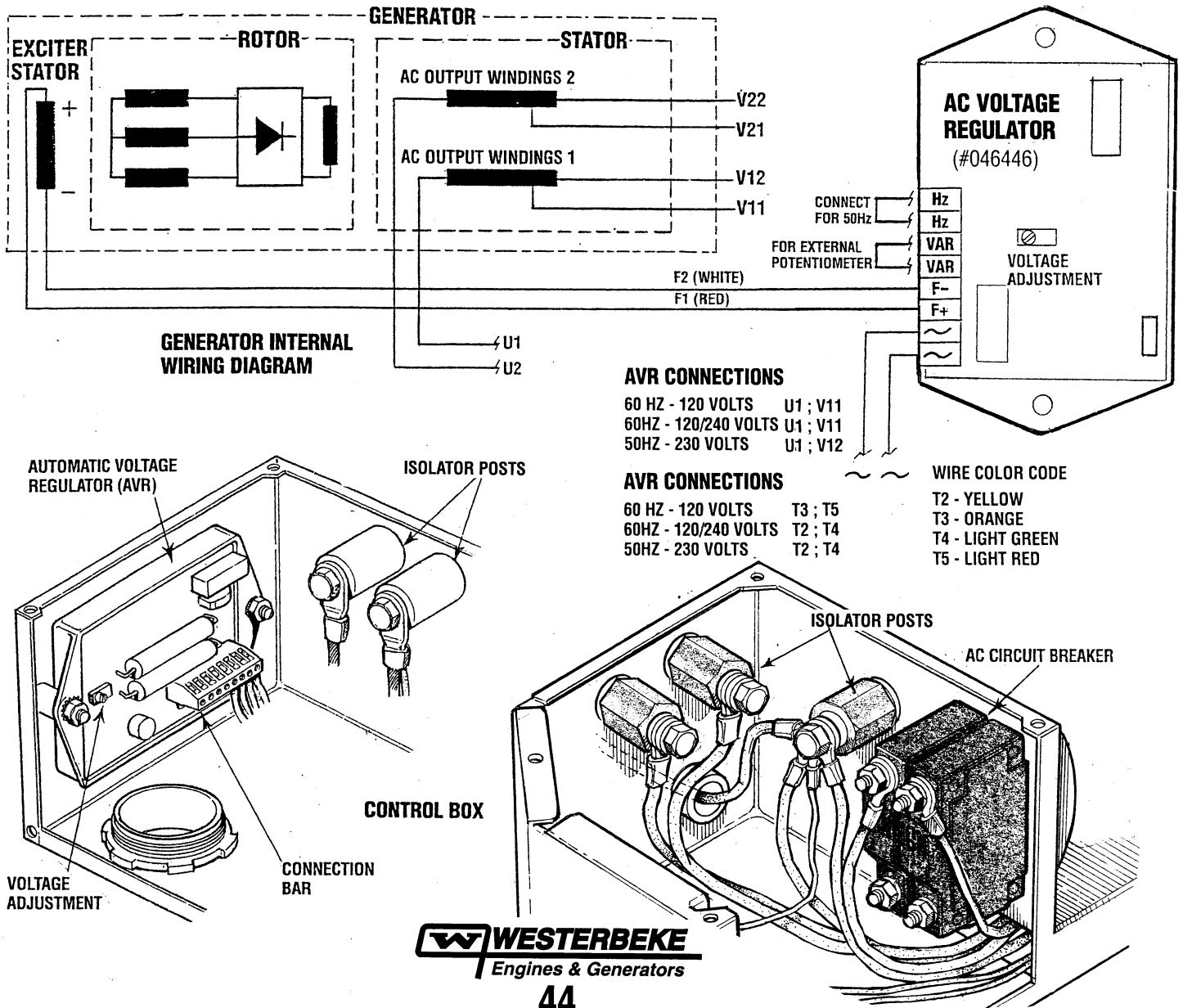

BE GENERATOR VOLTAGE CONNECTIONS

AC VOLTAGE CONNECTIONS

The frame ground wire (green) must be properly positioned when changing the AC output configuration of the AC terminal block. For making connections to the AC terminal block, use terminal ends for 1/4 inch studs that will accept multi strand copper wire sized for the amperage rating from the hot lead connection. The frame ground green wire connects between the neutral stud and the generator frame.

Generator Frequency

1. Frequency is a direct result of engine/generator speed:
1800 rpm = 60 hertz; 1500 rpm = 50 hertz.
2. To change generator frequency, follow the steps below:
Configure the AC terminal block for the desired voltage frequency as shown. Ensure that the case ground wire is connected to the correct terminal block neutral ground stud.
3. Remove or install the jumper on the automatic regulator (depending on frequency). Refer to *BE GENERATOR*.

NOTE: The green ground wire may be removed in those installations where the AC circuit has a separate neutral and ground circuit. This will prevent the unit from being a ground source in the vessel.

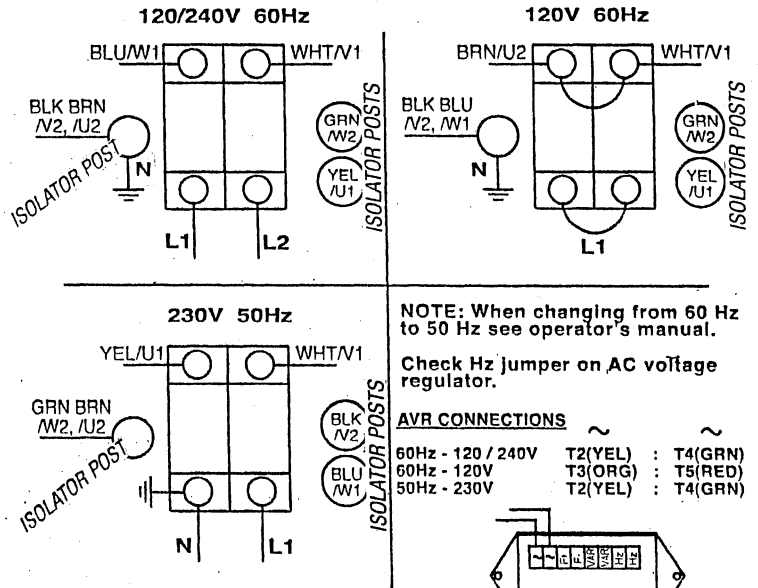

**VOLTAGE REGULATOR #046446
EARLIER MODELS**

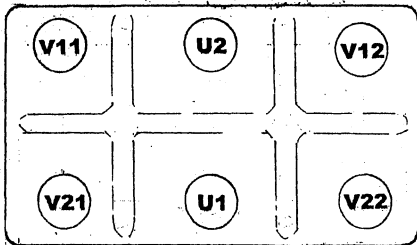

AC TERMINAL BLOCK

AC VOLTAGE CONNECTIONS BE GENERATORS EARLY MODELS

WARNING:

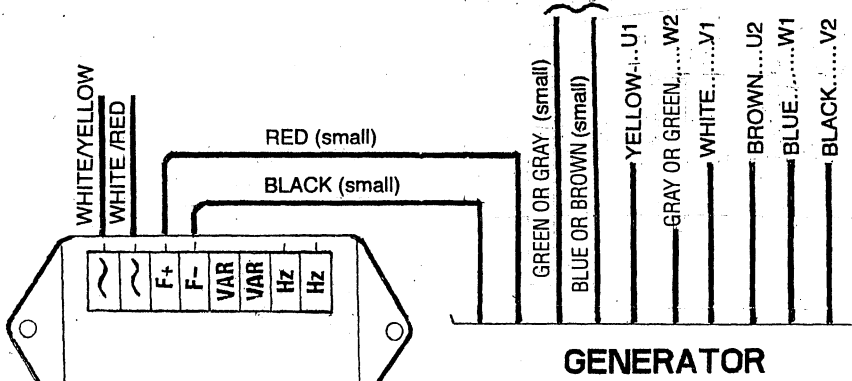

**VOLTAGE REGULATOR
#046446**

GENERATOR

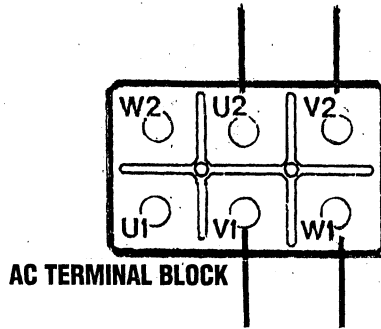

AC TERMINAL BLOCK

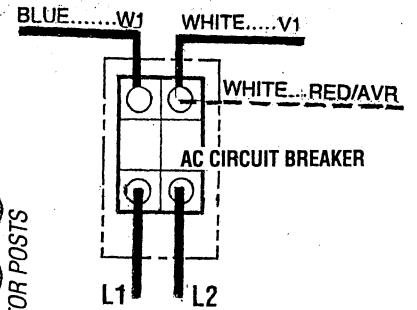

120/240V 60Hz

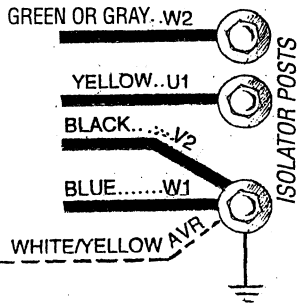
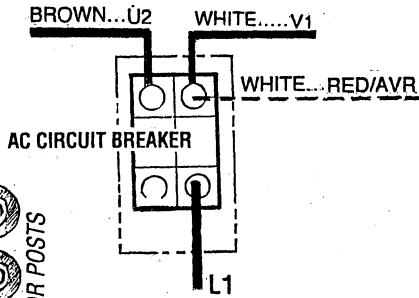
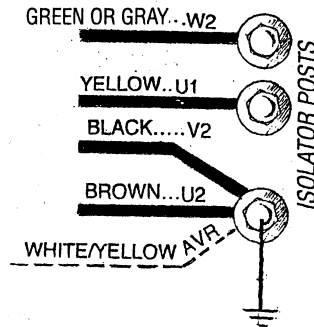

120V 60Hz

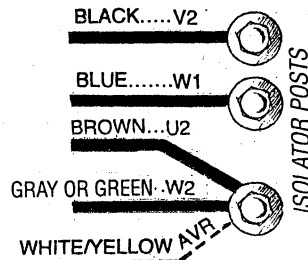
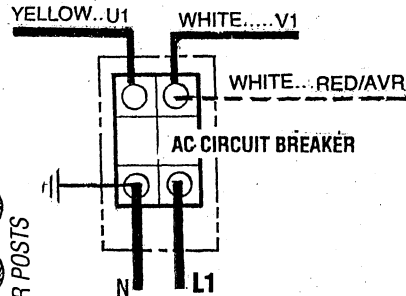

230V 50Hz

AC VOLTAGE REGULATOR

#046446

VOLTAGE POTENTIOMETER

The output voltage of the generator can be adjusted using the potentiometer with the generator running at its selected speed (frequency) by turning the adjustment until the desired voltage is obtained. **NOTE:** *If the voltage is set higher than selected rated voltage, the generator may be damaged.*

FREQUENCY

A jumper on the regulator is connected to two of the three pins for either 60 hertz or 50 hertz operation. **NOTE:** *This does not automatically change the engine speed. Engine speed change is performed using the adjustment on the belt driven mechanical governor.*

STABILITY

If at no-load or while under load with steady engine speed, AC output voltage fluctuation is experienced. Adjust the stability potentiometer. This modulates the reaction time of the regulator to external inputs, thereby eliminating any instability in the AC generator load system.

UNDER FREQUENCY

With the generator running at rated speed and producing desired voltage, reduce the engine speed using the mechanical governor by 4 hertz. Adjust the under frequency potentiometer until the AC output voltage of the generator starts to drop. Then restore the engine speed to the original rated speed.

VOLTAGE SENSING

The voltage sensing connections are 0 and 115 when selected output voltage is between 100V and 140V. Connect between 0 and 230 when selected output voltage is between 200V and 280V.

EXCITER WINDING

Proper polarity in this circuit **must** be maintained. **White** to F- and **red** to F+. Failure to do so may damage the regulator.

AUXILIARY WINDING

Connect the correct color wires to the terminals. Green or gray to Aux L and blue and brown to Aux N.

EXCITING THE GENERATOR

Exciting the generator using an external DC source can be performed when troubleshooting a generator/AC voltage output issue.

The following procedure should be followed:

1. The generator should not be operating. Remove the F- and F+ electrical connections off the regulator.
2. Maintaining polarity. Connect the + (plus) from a 9 volt dry cell battery to the red electrical lead coming from the generator and the - (negative) to the F- white electrical lead coming from the generator.
3. Start the generator and observe the reaction and voltage output from the generator and react accordingly.

The troubleshooting booklet for the BE style generator will help you determine the cause of a generator AC voltage output issue by the AC voltage found being produced by the generator and the reaction of the generation to excitation.

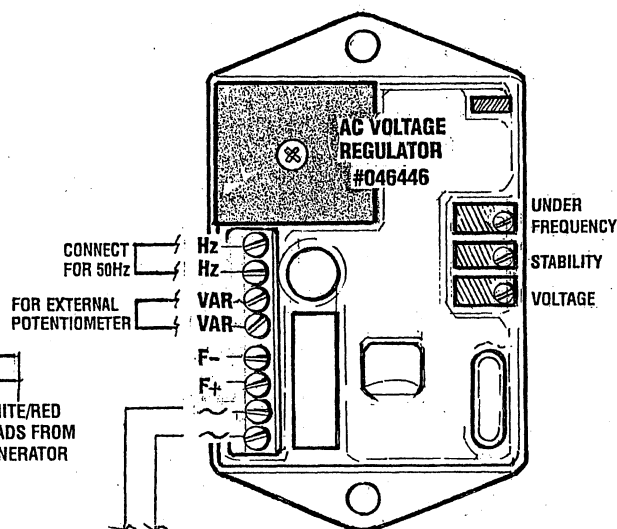
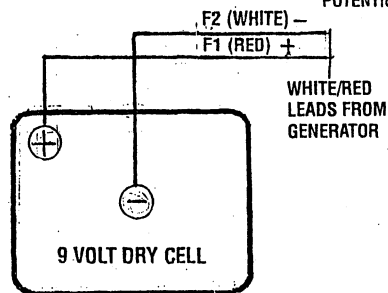

BE TROUBLESHOOTING

NOTE: AC GENERATOR TROUBLESHOOTING MUST BE PERFORMED WITH ENGINE OPERATING AT 60 HERTZ.

PROBLEM	PROBABLE CAUSE
<p>No AC voltage output at no load.</p>	<ol style="list-style-type: none"> 1. Short or open in the main stator winding. 2. Shorted pozi-resistor on exciter rotor. 3. Four or more shorted or open diodes on exciter rotor. 4. Open in exciter stator winding. 5. Open in rotating field winding.
<p>Residual voltage produced at no load 15 - 20 volts AC.</p>	<ol style="list-style-type: none"> 1. Faulty voltage regulator. 2. Short or open to wiring to voltage regulator. 3. Shorted or open main stator auxiliary winding.
<p>Low AC voltage output at no load 60 - 100 VAC.</p>	<ol style="list-style-type: none"> 1. Reset voltage potentiometer. 2. Open or shorted diodes in exciter rotor 1 to 3 diodes. 3. Open or shorted exciter rotor winding. 4. Faulty voltage regulator. 5. Short in exciter stator winding. 6. Short in rotating field winding.
<p>High AC output voltage 150 VAC or higher.</p>	<ol style="list-style-type: none"> 1. Reset voltage potentiometer. 2. Faulty voltage regulator.
<p>Unstable voltage output. Engine Speed Steady</p>	<ol style="list-style-type: none"> 1. Adjust voltage regulator. 2. Faulty voltage regulator.
<p>AC voltage drop under load 60 - 100 volts AC.</p>	<ol style="list-style-type: none"> 1. Diode(s) on exciter rotor. breaking down when load is applied (inductive) 1-3 diodes.

WESTERBEKE 8.0/6.4KW TO 14/11.6KW SBEG ENGINE SPECIFICATIONS

ENGINE SPECIFICATIONS

Engine Type	Gasoline, four-cycle, four-cylinder, fresh water-cooled, Vertical, in-line overhead mechanism	
Governor	Electromagnetic	
Combustion Chamber	Semi-spherical type	
Bore & Stroke	2.97 x 3.23 inches (75.5 x 82.0 mm).	
Piston Displacement	89.6 cubic inches (1468 cubic centimeters)	
Firing Order	1 - 3 - 4 - 2	
Direction of Rotation	Clockwise, when viewed from the front	
Compression Ratio	9.0:1	
Inclination	Continuous 20° temporary 30° (not to exceed 15 minutes)	
Fuel Consumption (at full amperage load approximate gph (lph))	8.0Kw 1.0 gph 10.0Kw 1.1 gph 12.5Kw 1.3 gph 14.0Kw 1.4 gph	6.4Kw (3.0 lph) 8.0Kw (3.5 lph) 10Kw (4.0 lph) 11.6Kw (4.5 lph)
Weight	8.0/6.4Kw 438 lbs (199 kgs) 8.0/10.0Kw 463 lbs (210 kgs) 10.0/12.5Kw 495 lbs (225 kgs) 11.6/14.0Kw 522 lbs (237 kgs)	

TUNE-UP SPECIFICATIONS

Compression Pressure (Limit of difference between cylinders)	165 psi at 300 rpm 14 psi
Valve Seat Angle	Intake 45° Exhaust 45°
Valve Clearance (engine hot)	Intake 0.08 inches (0.20 mm) Exhaust 0.09 inches (0.25 mm)
Engine Timing (1800 rpm)	15 BTDC (no vacuum advance connected. 33 - 35 with vacuum advance connected)
Horsepower Output All models 60Hz (50Hz)	24 hp (19 hp)

EXHAUST EMISSIONS SYSTEM

Emission Control Systems	EMC, OAS, TWC
--------------------------	---------------

LUBRICATION SYSTEM

General	Forced lubrication by geared pump
Oil Filter	Full flow, spin-on replaceable type
Sump Capacity (not including filter)	3.5 U.S. qts (3.3 liters) plus filter/cooler assembly
Operating Oil Pressure (engine hot)	20-60 psi
Oil Grade	API Specification of SJ.class

ELECTRICAL SYSTEM

Starter Battery	12-Volt, reduction gear/solenoid
Battery Capacity	800-1000 amps
Starter	12-Volt,(-) negative ground
DC Charging	12-VDC belt driven alternator
DC Cold Cranking Amps	150 - 175 (cold engine)

IGNITION SYSTEM

General	Battery ignition 12V negative ground. Distributor with ignition module and igniter. Ignition coil and spark plug.
Distributor	Equipped with auto timing controller, ignition coil built-in breakerless type
Spark Plug Thread Size	14mm X 1.25 pitch
Throttle Body	Electronic fuel injection with Electronic Governor
Spark Plug Gap	.030 inches (0.8 mm)

FUEL SYSTEM

General	Throttle body fuel injection
Fuel	Unleaded gasoline with an octane rating of 89 or higher.
Fuel Filter (on engine)	Replaceable cartridge-screw on
Air Cleaner (flame arrester)	Metal screen type - cleanable
Air Flow (engine combustion)	1800 rpm 47 cfm (1.3 cmm) 1500 rpm 39 cfm (1.1 cmm)
Fuel Hose Size	1/4" I.D. minimum - 3/8" I.D. maximum

COOLING SYSTEM

General	Fresh water-cooled block, thermostatically-controlled with heat exchanger.
Operating Temperature	170 - 190° F (77 - 88° C)
Fresh Water Pump	Centrifugal type, metal impeller, belt-driven
Raw Water Pump	Positive displacement, rubber impeller, belt driven
Raw Water Flow, at 1800 rpm	5.5 gpm (5.2 lpm) approx.
System Capacity (coolant)	6.0 qts (5.7 liters)

AC GENERATOR (SINGLE PHASE)

General-Single Phase	Brushless six pole, revolving field. Sealed lubricated single bearing design. Reconnectable single phase transformer with solid state voltage regulator	
Voltage - Single Phase	120 or 120/240 volts - 60 hertz 230 volts - 50 hertz	
Voltage Regulation	± 2% no load to full load.	
Frequency Regulation	± .5% no load to full load.	
Rating (Volts AC)		
8.0 /6.4 Kw	120/240 volts - 66/33	230 volts - 27amps
10.0/8.0 Kw	120/240 volts - 83/41	230 volts - 34 amps
12.5/10.0 Kw	120/240 volts - 104/52	230 volts - 43 amps
14.0/11.6 Kw	120/240 volts -116/58	230 volts - 50 amps
NOTE: Forced ventilation MUST be provided to maintain generator compartment temperatures below 122°F (50°C)		
Generator Cooling Air Requirements	200 - 300 cfm (5.6 - 8.4 cmm) (60 Hertz at 1800 RPM)	
NOTE: Increase air supply 15% for 50 hertz operation (1500 rpm)		
Engine Compartment Cooling Requirements	100 - 200 cfm (2.83 - 5.66 cmm)	

SHORE POWER TRANSFER SWITCH CONNECTIONS

SHORE POWER CONNECTIONS (60 HERTZ)

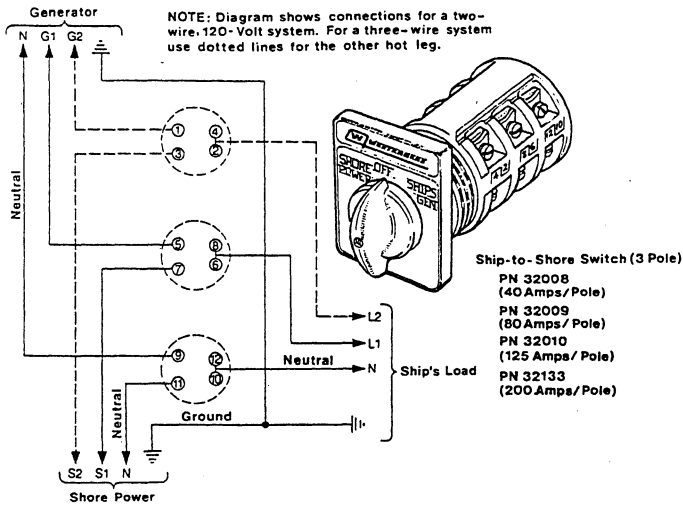

If the installer connects shore power to the vessel's AC circuit, this must be done by means of the Shore Power Transfer Switch. Set the transfer switch shown in the diagrams to the OFF position. This switch prevents simultaneous connection of shore power to generator output.

CAUTION: Damage to the generator can result if utility shore power and generator output are connected at the same time. This type of generator damage is not covered under the warranty; it is the installer's responsibility to make sure all AC connections are correct.

120 VOLT/60 HZ THREE WIRE CONFIGURATION

Notice the repositioning of the white wire ground load on the terminal block to the generator case.

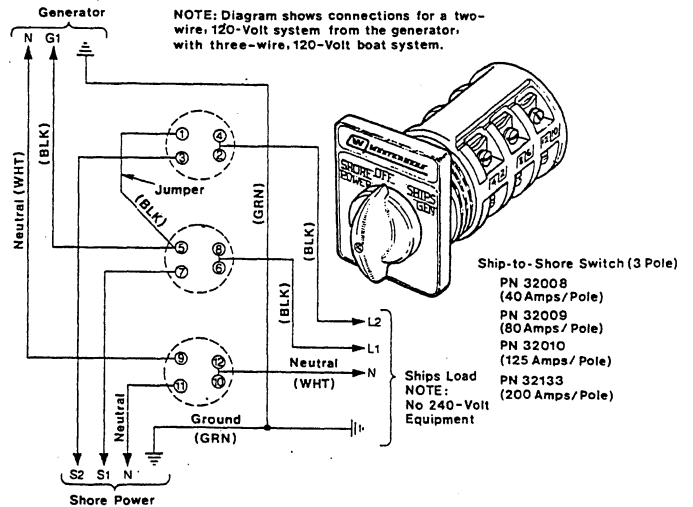

Switching Shore Power to Generator Power

CAUTION: Heavy motor leads should be shut off before switching shore power to generator power or vice-versa because voltage surges induced by switching with heavy AC loads on the vessel being operated may cause damage to the exciter circuit components in the generator.

230 VOLT/50 HERTZ TWO WIRE CONFIGURATION

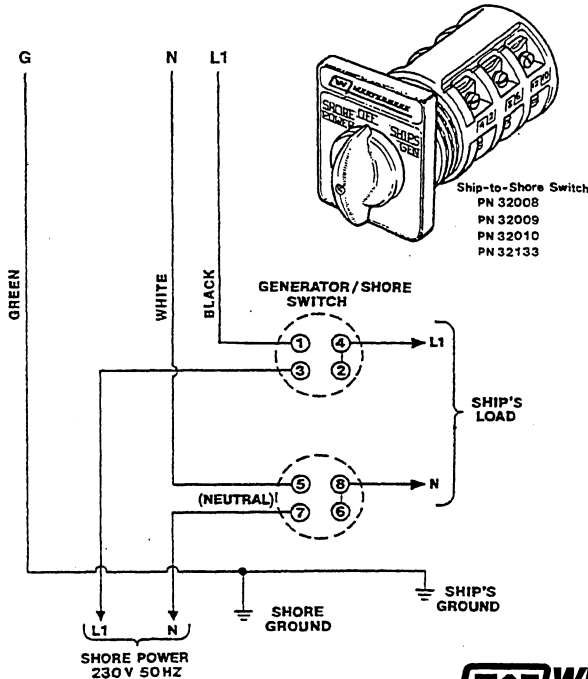

LAY-UP & RECOMMISSIONING

GENERAL

Many owners rely on their boatyards to prepare their craft, including engines and generators, for lay-up during the off-season or for long periods of inactivity. Others prefer to accomplish lay-up preparation themselves.

The procedures which follow will allow you to perform your own lay-up and recommissioning, or you may use them as a check list if others do the procedures.

These procedures should afford your engine protection during a lay-up and also help familiarize you with the maintenance needs of your engine.

If you have any questions regarding lay-up procedures, call your local servicing dealer; he will be more than willing to provide assistance.

Propeller Shaft Coupling [Propulsion Engine]

The transmission and propeller half couplings should always be opened up and the bolts removed when the boat is hauled out of the water or moved from land to water, and during storage in the cradle. The flexibility of the boat often puts a severe strain on the propeller shaft or coupling or both, while the boat is taken out or put in the water. In some cases, the shaft has actually been bent by these strains. This does not apply to small boats that are hauled out of the water when not in use, unless they have been dry for a considerable period of time.

Fresh Water Cooling Circuit [Propulsion Engine]

A 50-50 solution of antifreeze and distilled water is recommended for use in the coolant system at all times. This solution may require a higher concentration of antifreeze, depending on the area's winter climate. Check the solution to make sure the antifreeze protection is adequate.

Should more antifreeze be needed, drain an appropriate amount from the engine block and add a more concentrated mixture. Operate the engine to ensure a complete circulation and mixture of the antifreeze concentration throughout the cooling system. Now recheck the antifreeze solution's strength.

Lubrication System

With the engine warm, drain all the engine oil from the oil sump. Remove and replace the oil filter and fill the sump with new oil. Use the correct grade of oil. Refer to the *ENGINE LUBRICATING OIL* pages in this manual for the oil changing procedure. Run the engine and check for proper oil pressure and make sure there are no leaks.

⚠ CAUTION: Do not leave the engine's old engine oil in the sump over the lay-up period. Lubricating oil and combustion deposits combine to produce harmful chemicals which can reduce the life of your engine's internal parts.

Fuel System [Gasoline]

Top off your fuel tanks with *unleaded* gasoline of 89 octane or higher. A fuel conditioner such as Marine *Sta-Bil* gasoline stabilizer should be added. Change the element in your gasoline/water separator and clean the metal bowl. Re-install and make certain there are no leaks. Clean up any spilled fuel.

Fuel System [Diesel]

Top off your fuel tanks with No. 2D diesel fuel. Fuel additives such as *Bio-bor* and *Diesel Kleen + Cetane Boost* should be added at this time to control algae and condition the fuel. Care should be taken that the additives used are compatible with the primary fuel filter/water separator used in the system. Change the element in your primary fuel filter/water separator clean the separator sediment bowl.

Change the fuel filter elements on the engine and bleed the fuel system, as needed. Start the engine and allow it to run for 5 – 10 minutes to make sure no air is left in the fuel system. Check for any leaks that may have been created in the fuel system during this servicing, correcting them as needed. Operating the engine for 5 – 10 minutes will help allow movement of the treated fuel through the injection equipment on the engine.

Raw Water Cooling Circuit

Close the through-hull seacock. Remove the raw water intake hose from the seacock. Place the end of this hose into a five gallon bucket of clean fresh water. Before starting the engine, check the zinc anode found in the primary heat exchanger on the engine and clean or replace it as required, and also clean any zinc debris from inside the heat exchanger where the zinc anode is located. Clean the raw water strainer.

Start the engine and allow the raw water pump to draw the fresh water through the system. When the bucket is empty, stop the engine and refill the bucket with an antifreeze solution slightly stronger than needed for winter freeze protection in your area.

Start the engine and allow all of this mixture to be drawn through the raw water system. Once the bucket is empty, stop the engine. This antifreeze mixture should protect the raw water circuit from freezing during the winter lay-up, as well as providing corrosion protection.

Remove the impeller from your raw water pump (some antifreeze mixture will accompany it, so catch it in a bucket). Examine the impeller. Acquire a replacement, if needed, and a cover gasket. Do not replace the impeller (into the pump) until recommissioning, but replace the cover and gasket.

LAY-UP & RECOMMISSIONING

Starter Motor

Lubrication and cleaning of the starter drive pinion is advisable, if access to the starter permits its easy removal. Make sure the battery connections are shut off before attempting to remove the starter. Take care in properly replacing any electrical connections removed from the starter.

Cylinder Lubrication [Diesel]

If you anticipate a long lay-up period (12 months or more) WESTERBEKE recommends removal of the glow plugs for access to the cylinders. Squirt some Marvel Mystery Oil into the cylinder walls. Rotate the engine crankshaft by hand two revolutions and re-install the glow plugs.

If your engine does not have glow plugs, the injectors will have to be removed. Be sure to have replacement sealing washers for the injectors and return fuel line as needed.

Intake Manifold [Gasoline]

Clean the filter screen in the flame arrester, and place a clean cloth lightly soaked in lube oil around the flame arrester to block any opening. Also place an oil-soaked cloth in the through-hull exhaust port. Make a note to remove cloths prior to start-up!

Cylinder Lubrication [Gasoline]

Remove the flame arrester screen and with the engine operating, spray fogging oil into the intake opening stalling the engine. Replace the intake screen.

NOTE: At Spring commissioning, remove and clean and gap the spark plugs. Rotate the engine two complete revolutions. Re-install the spark plugs, tighten properly and connect the high tension leads fully onto each spark plug.

Batteries

If batteries are to be left on board during the lay-up period, make sure that they are fully charged, and will remain that way, to prevent them from freezing. If there is any doubt that the batteries will not remain fully charged, or that they will be subjected to severe environmental conditions, remove the batteries and store them in a warmer, more compatible environment.

⚠ WARNING: Lead acid batteries emit hydrogen, a highly-explosive gas, which can be ignited by electrical arcing or a lighted cigarette, cigar, or pipe. Do not smoke or allow an open flame near the battery being serviced. Shut off all electrical equipment in the vicinity to prevent electrical arcing during servicing.

Transmission [Propulsion Engine]

Check or change the fluid in the transmission as required. Wipe off grime and grease and touch up any unpainted areas. Protect the coupling and the output flange with an anti-corrosion coating. Check that the transmission vent is open. For additional information, refer to the TRANSMISSION SECTION.

Spare Parts

Lay-up time provides a good opportunity to inspect your Westerbeke engine to see if external items such as drive belts or coolant hoses need replacement. Check your basic spares kit and order items not on hand, or replace those items used during the lay-up, such as filters and zinc anodes. Refer to the SPARE PARTS section of this manual.

Recommissioning

The recommissioning of your Westerbeke engine after a seasonal lay-up generally follows the same procedures as those described in the PREPARATIONS FOR STARTING section regarding preparation for starting and normal starts. However, some of the lay-up procedures will need to be counteracted before starting the engine.

1. Remove the oil-soaked cloths from the intake manifold.
2. Remove the raw water pump cover and gasket and discard the old gasket. Install the raw water pump impeller removed during lay-up (or a replacement, if required). Install the raw water pump cover with a new cover gasket.
3. Reinstall the batteries that were removed during the lay-up, and reconnect the battery cables, making sure the terminals are clean and that the connections are tight. Check to make sure that the batteries are fully charged.

⚠ CAUTION: Wear rubber gloves, a rubber apron, and eye protection when servicing batteries. Lead acid batteries emit hydrogen, a highly explosive gas, which can be ignited by electrical arcing or a lighted cigarette, cigar, or pipe. Do not smoke or allow an open flame near the battery being serviced. Shut off all electrical equipment in the vicinity to prevent electrical arcing during servicing.

4. Remove the spark plugs, wipe clean, re-gap, and install to proper tightness [gasoline].
5. Check the condition of the zinc anode in the raw water circuit and clean or replace the anode as needed. Note that it is not necessary to flush the antifreeze/fresh water solution from the raw water coolant system. When the engine is put into operation, the system will self-flush in a short period of time with no adverse affects. It is advisable, as either an end of season or recommissioning service, to inspect the area where the zinc is located in the heat exchanger and clear any and all zinc debris from that area.
6. Start the engine in accordance with procedures described in the PREPARATIONS FOR STARTING section of this manual.

CARBON MONOXIDE "CO"/ LOW-CO GENERATORS

IMPORTANT INFORMATION

DESCRIPTION

Carbon monoxide "CO" is a component of engine exhaust. It is a colorless, tasteless, odorless, lighter than air poisonous gas that can kill you without any warning. CO poisoning is one of the major safety risks associated with boating. It is a threat that must not be underestimated.

Westerbeke *Low Co* generators are designed to reduce normal levels of CO in the engine exhaust by approximately 99%.

Several standards for CO have been published, expressed in parts per million "ppm" and hours of exposure:

Regulator	CO ppm	Exposure Hours
EPA	9	8
ACGIH	25	8
EPA	35	1
NIOSH	35	8
OSHA	50	8
ACGIH	125	0.5
NIOSH	200	0.0
NIOSH (IDLH)	1200	0.0

1200 ppm is the so-called IDLH concentration - IMMEDIATELY DANGEROUS TO LIFE AND HEALTH.

A city in California characterizes the effect of CO concentration this way:

Parts per Million	Responses
25	Permissible exposure level, no apparent toxic symptoms.
100	No poisoning for long period. Allowable for several hours.
200	Should not be exposed above this level for any period of time. A possible mild frontal headache in two to three hours.

Even though the generator normally produces very low levels, Westerbeke *Low Co* generators are designed to reduce normal levels of CO in the engine exhaust by approximately 99%. An exhaust leak of untreated exhaust would be extremely dangerous. For this reason it is extremely important to install a CO detector near the generator and to be sure it is always turned on and functioning properly. If this detector sounds, do not turn it off, assuming it is a false signal. You can not taste, smell, or otherwise detect CO. Leave the detector on, turn off all engines and generators, evacuate the boat leaving ports and hatches open, and seek professional help.

As soon as CO leaves the exhaust outlet, the level is subject to dilution in the open air. The closer a person is to the exhaust outlet, the higher the concentration of CO.

In a closed space, such as the engine compartment, the boat, or underneath a stern swim platform, concentrations will potentially rise to the undiluted level emanating from the exhaust system due to a lack of fresh air to dilute the exhaust gas. Therefore, one should never rely on dilution of the exhaust to provide a margin of safety.

Westerbeke *low Co* generators achieve an approximate 99% reduction of typical CO by precise control of the engine's air/fuel ration coupled with after treatment in a special catalyst. CO emissions are not the same for every model because each engine is different. Also, certain fuel system components are commonized across several engine models being adequate for some and extra-adequate for others, thus producing different CO levels for different models.

The fuel system which accomplishes the required precise air/fuel ratio control is comprised of many different components: purchased sub-assemblies, machined castings, sensors, electronics and others. Because of the extreme level of CO reduction, any variability in the functioning of any these components can and will cause variability of the CO output.

CO concentration also varies with load. Usually, but not always, the worst case CO concentration occurs at maximum load.

INSPECTION

The catalyst is critical to optimizing CO levels. Any water intrusion into the exhaust system will likely quickly compromise the proper operation of the catalyst. Westerbeke's exhaust system installation instructions dated on or after February 2004 must be adhered to.

NOTE: *Water intrusion is not a product defect and is not covered under warranty, neither Westerbeke's normal product warranty nor the emissions specific warranty mandated by various regulating authorities such as EPA and CARB.*

Maintenance of any components affecting the flow of air or the flow of fuel to the engine is critically important, such as fuel filters and air filters (if any).

Inspection of the catalyst at the prescribed intervals is critically important. The exhaust elbow is removed by loosening the metal clamp to provide a view of the output surface of the catalyst. Any visual irregularity of the normal flush, honeycomb appearance is most likely a result of water intrusion. The cause of the irregularity must be identified and addressed. If there is irregularity, the catalyst and gasket must be replaced. Upon careful reassembly of the catalyst, exhaust elbow gasket, and exhaust elbow, check for the presence of CO while the engine is running. This must be performed with a CO analyzer.

CARBON MONOXIDE "CO"/ LOW-CO GENERATORS

IMPORTANT INFORMATION

Catalyst performance will degrade over time. As the generator accumulates operating hours, CO concentrations will increase. **The catalyst must be replaced every 2,000 hours of engine operation.**

Verification of satisfactory CO levels must be done seasonally or each 1,000 hours (which ever occurs first). Verification involves actual sampling of exhaust gas with an appropriate CO analyzer.

There are two locations where exhaust gas can be sampled. Dry, but hot, exhaust can be sampled at the plugged tapped hole in the exhaust elbow intended for back pressure measurements. Measurements at this location may not be practical in all instances due to the high exhaust temperature, temperature limits of the analyzer, safety concerns over temperatures involved or the possibility of high levels of CO. The other location is the boat's exhaust outlet, which contains entrained cooling water (except dry stack exhaust systems). Only analyzers with probes should be used at this location and it is critical that the probe not ingest water. Probe-type analyzers have an air pump drawing a gas sample through the probe. As a result, they tend to ingest water when it is present. Be sure to aim the probe downwards with the opening pointed in the direction of the water flow and just out of the flow. Position the analyzer as high as possible with the tubing leading to the probe running continuously downhill. Observe the usually translucent tubing between the probe and the analyzer and be sure no water is being ingested. If any water is ingested into the analyzer, it must be repaired or replaced and recalibrated.

When measuring CO at the exhaust outlet be aware of the ambient CO level by also measuring CO away from and upwind of the exhaust outlet, especially in marinas. the CO level at the exhaust will be influenced upwards by the ambient level.

Whenever taking the time to verify proper CO concentration from the exhaust with a CO analyzer, always take the opportunity to use the analyzer to "sniff" around the engine looking for CO from exhaust leaks. Pay close attention to the connection of the cylinder head to the exhaust manifold, the exhaust manifold to the water injected exhaust elbow, and all subsequent downstream exhaust components and hoses. Remember, exhaust gas that has not yet passed through the catalyst is raw, untreated exhaust and is very high in CO content.

Analyzers usually require periodic calibration. Follow the instructions that come with the analyzer very carefully regarding calibration.

The following are manufacturers that offer CO analyzers: Extech, TIF, Testo, TSI, Bacharach, Fluke, Monoxor, Fyrite, Zellweger Analytics, Industrial Scientific Corp, GFG, TPI, Teledyne and others. Westerbeke recommends analyzers with a probe connected to the analyzer by a length of transparent tubing. They are slightly more expensive than those with the sensor built into one end of the analyzer, but they allow you to sample the exhaust coming out of the boat's exhaust outlet.

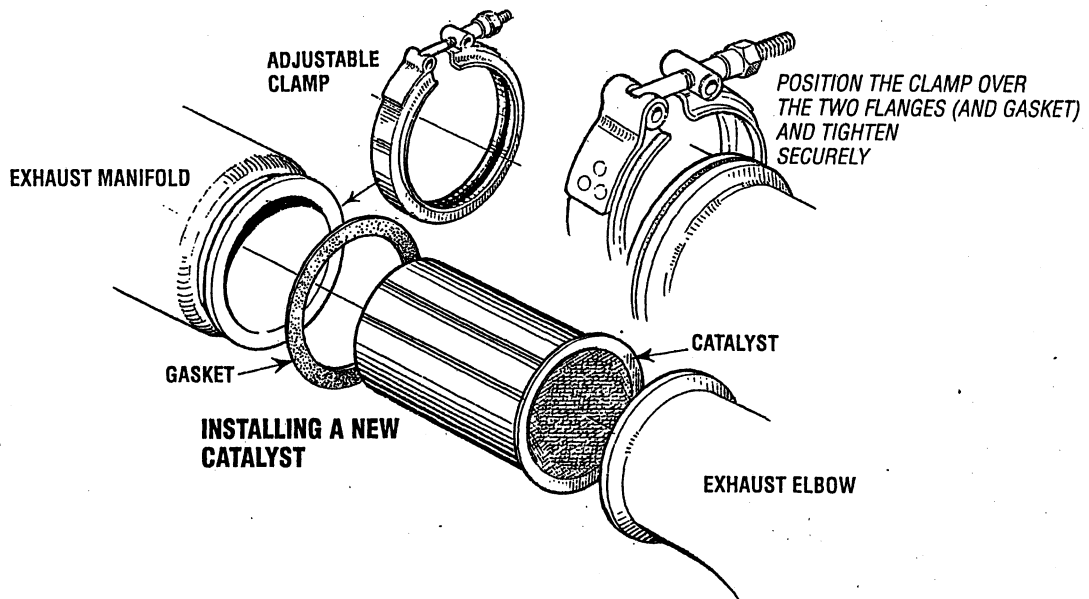

EMISSIONS

This genset meets the requirements of California's Exhaust Emissions Standards as stated on the nameplate.

California users of this genset should be aware that unauthorized modifications or replacement of fuel, exhaust, air intake, or speed control system components that affect engine emissions are prohibited. Unauthorized modification, removal or replacement of the engine label is prohibited.

Federal Emissions Compliance Period: The Federal Emissions Compliance Period referred to on the nameplate indicates the number of operating hours for which the engine has been shown to meet Federal Emissions requirements.

Category C= 250 hrs, B=500 hrs, m A =1000.hrs.

You should carefully review operator (Owner) Installation and other manuals and information you receive with your genset. If you are unsure that the installation, use, maintenance or service of your genset is authorized, you should seek assistance from an approved WESTERBEKE dealer.

California genset users may use the table below as an aid in locating information related to the California Air Resources Board requirements for emissions control.

EMISSIONS CONTROL INFORMATION TABLE

Emissions Warranty Information	The California emissions control warranty statement is located in the same packet, if information as this manual when the genset is shipped from the factory.
Engine Fuel Requirements	The engine is certified to operate on unleaded gasoline. See <i>FUEL RECOMMENDATIONS</i> .
Engine Valve Adjustment	See <i>MAINTENANCE SCHEDULE</i> .
Engine Ignition Timing	See <i>MAINTENANCE SCHEDULE</i> .
Engine Lubricating Oil Requirements	See <i>ENGINE OIL RECOMMENDATIONS</i> .
Engine Adjustments	ECU.
Engine Emission Control System	The engine emission control system consists of engine design and precision manufacture.
Catalyst	See <i>MAINTENANCE SCHEDULE</i> .
Oxygen Sensor	See <i>MAINTENANCE SCHEDULE</i> .
Back Pressure	See <i>MAINTENANCE SCHEDULE</i> .

ENGLISH TO METRIC CONVERSION CHART

Multiply Temperature	By	To get equivalent number of:
Degree Fahrenheit (°F)	(°F-32) ÷ 1.8	Degree Celsius (°C)
Multiply Acceleration	By	To get equivalent number of:
Foot/second ² (ft/sec ²)	0.3048	Meter/second ² (m/s ²)
Inch/second ² (in./sec ²)	0.0254	Meter/second ² (m/s ²)
Multiply Torque	By	To get equivalent number of:
Pound-inch (lb-in.)	0.11298	Newton-meters (N-m)
Pound-foot (lb-ft)	1.3558	Newton-meters (N-m)
Multiply Power	By	To get equivalent number of:
Horsepower (hp)	0.746	Kilowatts (kW)
Multiply Pressure or Stress	By	To get equivalent number of:
Inches of water (in. H ₂ O)	0.2491	Kilopascals (kPa)
Pounds/square in. (lb/in. ²)	6.895	Kilopascals (kPa)
Multiply Energy or Work	By	To get equivalent number of:
British Thermal Unit (Btu)	1055	Joules (J)
Foot-pound (ft-lb)	1.3558	Joules (J)
kilowatt-hour (kW-hr)	3,600,000. or 3.6 x 10 ⁶	Joules (J = one W/s)
Multiply Light	By	To get equivalent number of:
Foot candle (fc)	1.0764	Lumens/meter ² (lm/m ²)
Multiply Fuel Performance	By	To get equivalent number of:
Miles/gal (mile/gal)	0.4251	Kilometers/liter (km/L)
Gallons/mile (gal/mile)	2.3527	Liter/kilometer (L/km)
Multiply Velocity	By	To get equivalent number of:
Miles/hour (mile/hr)	1.6093	Kilometers/hour (km/hr)

Multiply Length	By	To get equivalent number of:
Inch (in.)	25.4	Millimeters (mm)
Foot (ft)	0.3048	Meters (m)
Yard (yd)	0.9144	Meters (m)
Mile (mile)	1.609	Kilometers (km)
Multiply Area	By	To get equivalent number of:
Inch ² (in. ²)	6452	Millimeters ² (mm ²)
Inch ² (in. ²)	6.45	Centimeters ² (cm ²)
Foot ² (ft ²)	0.0929	Meters ² (m ²)
Yard ² (yd ²)	0.8361	Meters ² (m ²)
Multiply Volume	By	To get equivalent number of:
Inch ³ (in. ³)	16387	Millimeters ³ (mm ³)
Inch ³ (in. ³)	16.387	Centimeters ³ (cm ³)
Inch ³ (in. ³)	0.0164	Liters (L)
Quart (qt)	0.9464	Liters (L)
Gallon (gal)	3.785	Liters (L)
Yard ³ (yd ³)	0.7646	Meters ³ (m ³)
Multiply Mass	By	To get equivalent number of:
Pound (lb)	0.4536	Kilograms (kg)
Ton (ton)	907.18	Kilograms (kg)
Ton (ton)	0.907	Tonne (t)
Multiply Force	By	To get equivalent number of:
Kilogram (kg)	9.807	Newtons (N)
Ounce (oz)	0.2780	Newtons (N)
Pound (lb)	4.448	Newtons (N)

SUGGESTED SPARE PARTS

WESTERBEKE MARINE GASOLINE GENERATORS

CONTACT YOUR WESTERBEKE DEALER FOR SUGGESTIONS AND ADDITIONAL INFORMATION

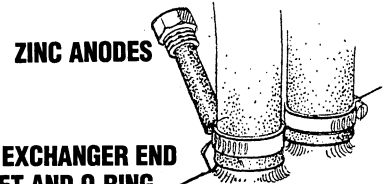
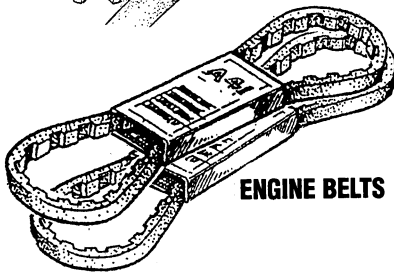
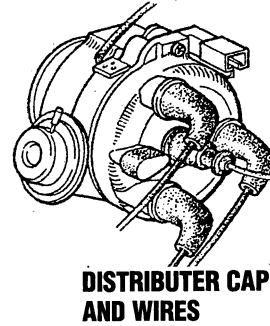
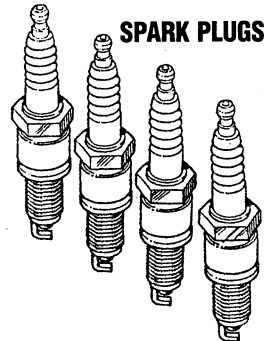
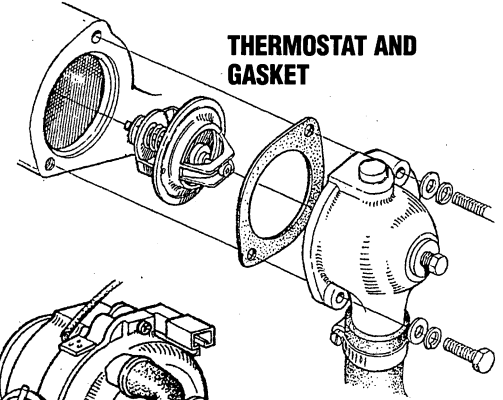
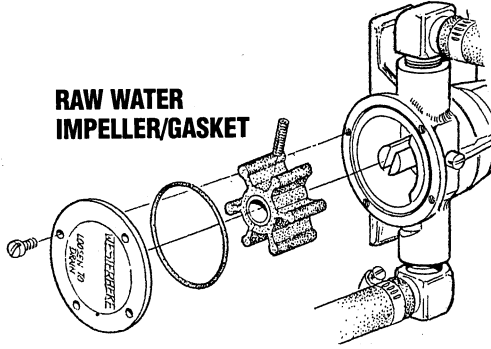
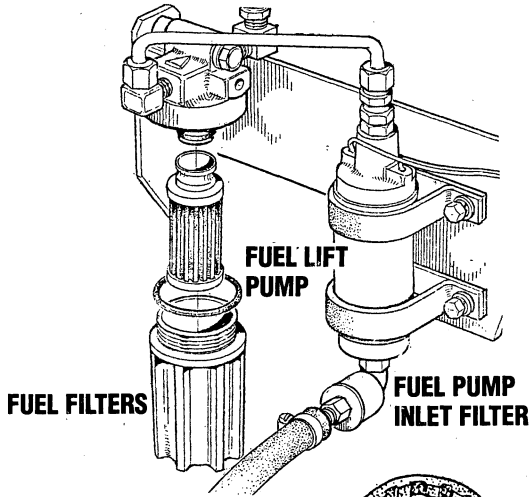

MOLDED HOSE KIT IN A CANVAS CARRYING BAG

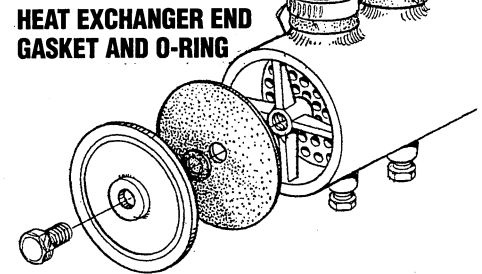
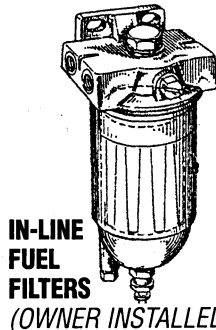
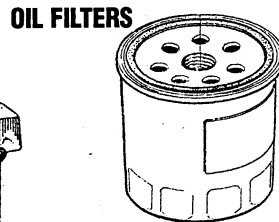

WESTERBEKE RECOMMENDS CARRYING ENOUGH SPARE ENGINE OIL (YOUR BRAND) FOR AN OIL CHANGE (5 QTS.) AND A GALLON OF PREMIXED COOLANT.

SPARE PARTS KITS

WESTERBEKE also offers two Spare Parts Kits, each packaged in a rugged, rust free toolbox.

KIT A includes the basic spares.

KIT B is for more extensive off-shore cruising.

KIT A

- Impeller Kit
- Heat Exchanger Gasket
- Oil Filter
- Drive Belt
- Zinc Anodes
- Spark Plugs

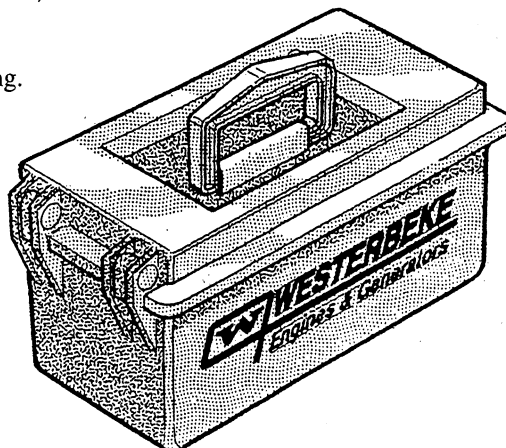

KIT B

- Impeller Kit
- Water Pump Repair Kit
- Thermostat Kit
- Zinc Anodes
- Complete Gasket Kit
- Heat Exchanger Gasket
- Oil Filter
- Drive Belt
- Spark Plugs

