

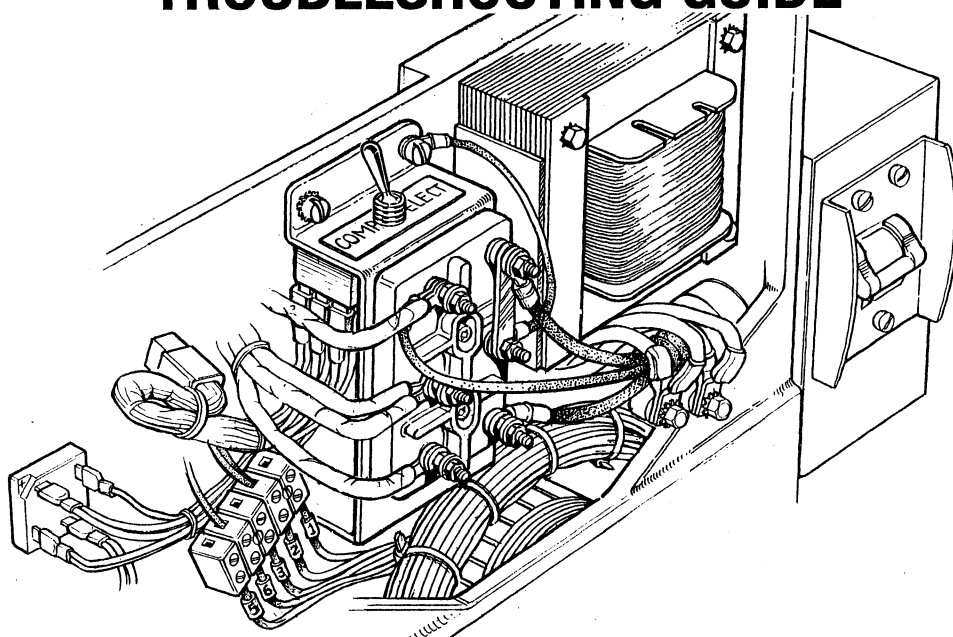

# BT GENERATORS

**SIX AND TWELVE STUD TERMINAL BLOCKS**

**AC ELECTRICAL TESTING,  
ADJUSTMENTS, and  
TROUBLESHOOTING GUIDE**



WESTERBEKE CORPORATION • MYLES STANDISH INDUSTRIAL PARK  
150 JOHN HANCOCK ROAD, TAUNTON, MA 02780-7319 U.S.A.  
TEL: (508)823-7677 • FAX: (508)884-9688 • WEBSITE: WWW.WESTERBEKE.COM



Member National Marine Manufacturers Association

2ND EDITION  
JULY 2014

# TABLE OF CONTENTS

<b>THE BT GENERATOR INTRODUCTION</b> .....	2
Description .....	2
<b>BT GENERATOR TROUBLESHOOTING CHARTS (6/12 STUD)</b> .....	3
Preliminary Checking .....	3
Troubleshooting Sequence (chart) .....	3
<b>INTERNAL WIRING SCHEMATIC (6 STUD)</b> .....	4
Component Resistance .....	4
<b>INTERNAL WIRING SCHEMATIC (12 STUD)</b> .....	5
Component Resistance .....	5
<b>MEASURING RESIDUAL VOLTAGE (6/12 STUD)</b> .....	6
12 Volt Excitation .....	6
Bridge Rectifier Wiring .....	6
<b>TESTING EXCITER STATOR WINDINGS (6/12 STUD)</b> .....	7
Testing Windings Resistance .....	7
Measuring the Exciter Stator Windings (12 stud) .....	7
Testing the Bridge Rectifier .....	7
<b>TESTING EXCITER ROTOR WINDINGS (6/12 STUD)</b> .....	8
Testing Auxiliary Windings .....	8
Testing Rotor Field Windings .....	8
<b>TESTING DIODES AND THERMISTERS (6/12 STUD)</b> .....	9
Testing Diodes .....	9
Testing the Thermister .....	9
<b>TESTING STATOR WINDINGS (6/12 STUD)</b> .....	10
Main Stator Windings .....	10
Main Stator Auxiliary Windings (6 stud) .....	10
Main Stator Auxiliary Windings (12 stud) .....	10
<b>COMPOUND TRANSFORMER (6/12 STUD)</b> .....	11
Measuring Resistance (6 stud) .....	11
Transformer Auxiliary Windings (12 stud) .....	11
Compound Transformer (6/12 stud) .....	11
Measuring Resistance .....	11
<b>VOLTAGE ADJUSTMENT</b> .....	12
No-load Voltage Adjustment .....	12
Full-load Voltage Adjustment .....	12
Changing Frequency/Hertz .....	12
AVR Selector Switch and Plug Connections (6/12 STUD) .....	12
<b>AC TERMINAL BLOCK CONNECTIONS (6/12 STUD)</b> .....	13
Winding Diagrams (6 stud) .....	13
Winding Diagrams (12 stud) .....	13

# THE BT GENERATOR

## INTRODUCTION

### DESCRIPTION

The BT generator is a four-pole, brushless, self-excited generator which requires only the driving force of the engine to produce AC output. The copper and laminated iron in the exciter stator are responsible for the self-exciting feature of this generator. The magnetic field produced causes an AC voltage to be induced into the related exciter rotor windings during rotation. Diodes located in the exciter rotor rectify this voltage to DC and supply it to the windings of the rotating field. This creates an electromagnetic field which rotates through the windings of the main stator, inducing an AC voltage which is supplied to a load. A step down transformer is connected in parallel to the AC output of the main stator. An AC voltage is produced in the auxiliary windings of the transformer and the main stator and is, in turn, supplied to a full-wave bridge rectifier. The rectifier produces a DC voltage to further excite the exciter stator windings, enabling the generator to produce a rated AC output.

The generator's data plate gives the voltage, current and frequency rating of the generator. An AC wiring decal is affixed to the inside of the louvered cover at the generator end. A diagram of the various AC voltage connections is provided on the decal. These diagrams are also illustrated in this manual.

### VOLTAGE REGULATOR (AVR)

A solid state voltage regulator that works in tandem with the transformer regulator to produce a more stable AC output is available [optional] on the 6 stud terminal board generator.

### 6 AND 12 STUD [TERMINAL BLOCK] GENERATORS

This electrical testing/troubleshooting guide includes both the 6 and 12 stud BT generators. Most of the text is identical for both generators and where there is a difference it is clearly identified.

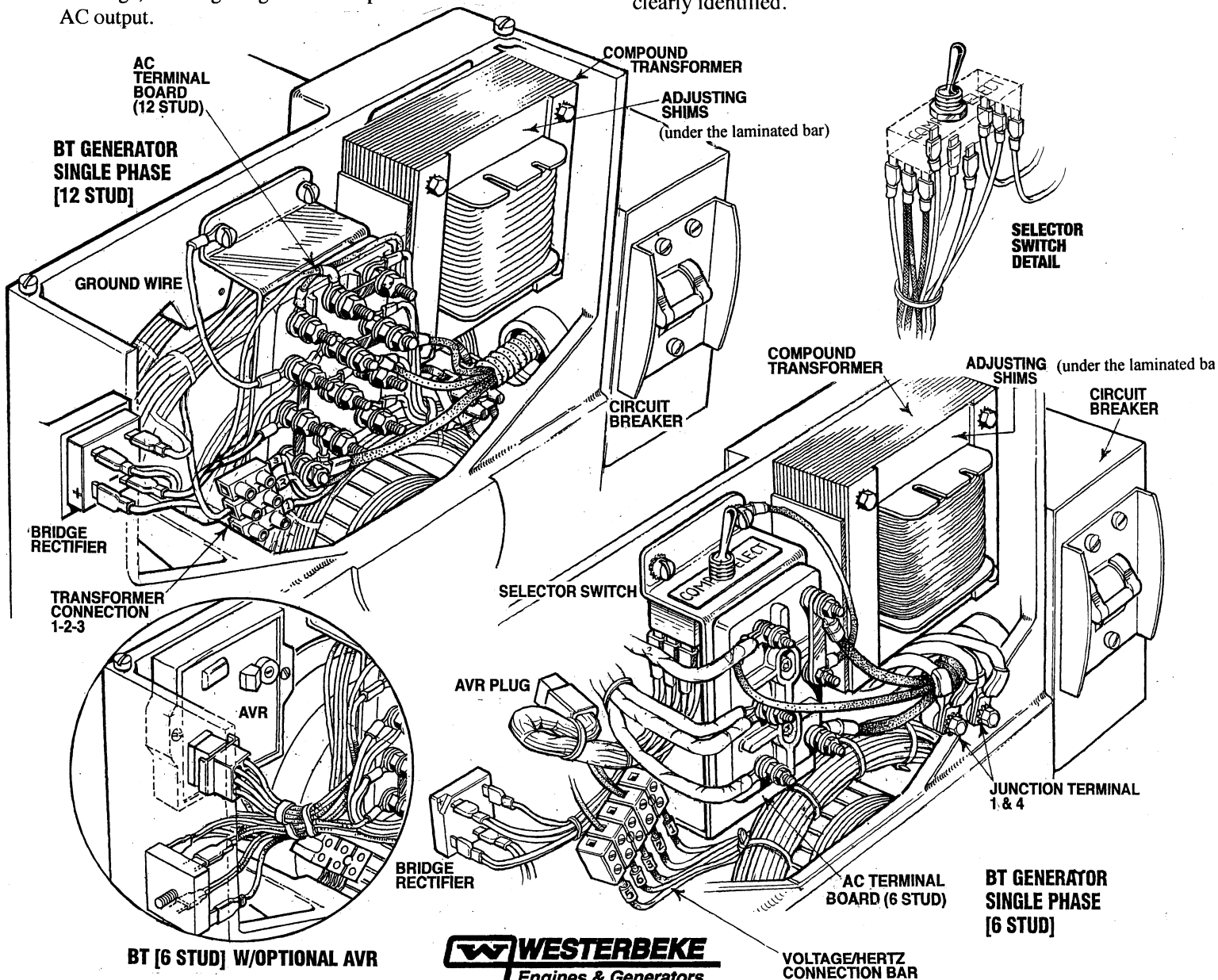

BT [6 STUD] W/OPTIONAL AVR

# BT GENERATOR TROUBLESHOOTING CHARTS

(FOR 6 AND 12 STUD TERMINAL BLOCK GENERATORS)

## PRELIMINARY CHECKING

Before electrical testing check for proper engine speed/hertz adjustment. Low engine speed will cause low AC voltage output, high engine speed-high AC output.

Refer to WESTERBEKES operators manual or service manual for engine speed/hertz adjustment or for other possible engine related problems.

Before testing, get a clear explanation of the problem that exists, be certain it relates to generator components.

## TROUBLESHOOTING

The test procedures on the following pages can be used to troubleshoot WESTERBEKES 6 and 12 stud (terminal block) BT generators.

Due to the simplicity of the generators design troubleshooting is relatively simple and field testing and repairing can be accomplished with basic tools and repair parts which should include the following:

**A quality multimeter [multitester]** capable of reading less than one ohm and with a specific diode testing function.

**Basic electrical tools** including cutters, soldering iron, wire stripper/crimper, terminals connectors, etc.

**Repair parts** such as diodes, suppressors, fuses, bridge rectifier, etc.

---

## TROUBLESHOOTING SEQUENCE

The **bold** letters and numbers refer to the components of the *internal wiring schematics* and also to the *component resistance charts* in the following pages

### LOW VOLTAGE (60-100 VOLTS-AC/60Hz - 115-200VOLTS/50Hz) TEST COMPONENTS IN THE FOLLOWING ORDER:

**F** Selector Switch (6 stud only)

**B** Exciter Rotor:

**2** Diodes (6), **3** Field Windings, **1** Exciter Windings **a b c**

**A** Exciter Stator Windings **1-1+2**

### NO AC VOLTAGE OUTPUT (EXTREMELY LOW VOLTAGE 1-5 VOLTS) TEST COMPONENTS IN THE FOLLOWING ORDER:

**C** Main Stator Windings **1+2**

**B** Thermister **4**

**2** Diodes (**4-6** open/shorted)

**D** Compound Transformer Winding **1+2**

**B** Rotor Field Winding **3**

### RESIDUAL VOLTAGE TEST COMPONENTS IN THE FOLLOWING ORDER:

**A** Exciter Stator Windings **1-1+2**

**G** Bridge Rectifier

**D** Transformer Aux. Winding **3**

**C** Main Stator Aux. Winding **3**

**Check Also:** *Circuit connections from the transformer to the connections on the Bridge Rectifier.*

# INTERNAL WIRING SCHEMATIC (6 STUD) BT GENERATOR W/OPTIONAL VOLTAGE REGULATOR

REFER TO THE TROUBLESHOOTING CHART ON PAGE 3 FOR THE RECOMMENDING COMPONENT TESTING SEQUENCE

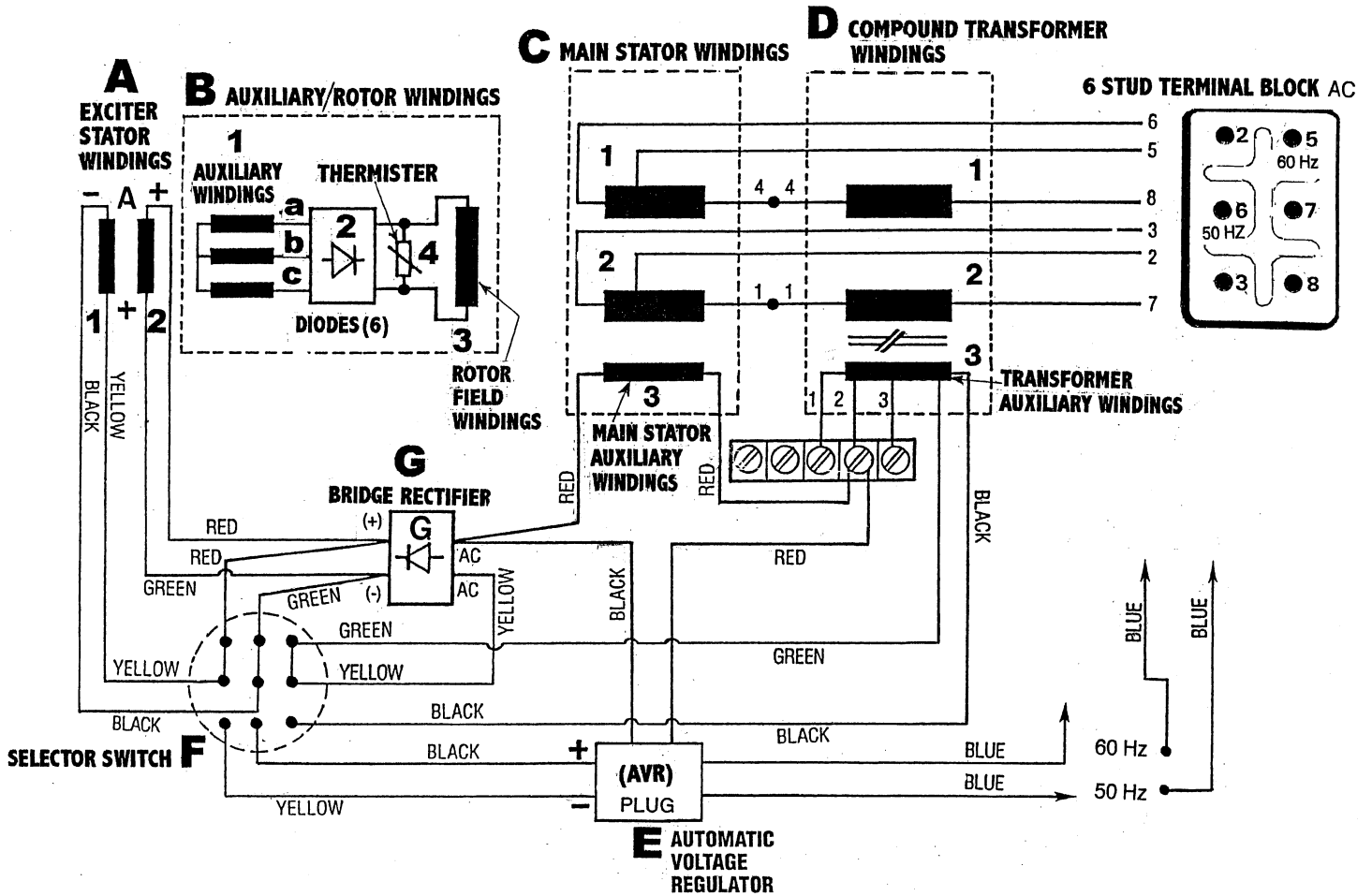

## COMPONENT RESISTANCE (IN OHMS)

### A EXCITER STATOR WINDINGS

- 1 and 2....11.5 Ω
- 1....49.4 Ω
- 2....12.9 Ω

### B EXCITER ROTOR AND FIELD WINDINGS

- 1 a b c auxiliary windings are measured in pairs:  
a-b....1.5 Ω, b-c....1.5 Ω, c-a....1.5 Ω
- 2 Diodes (6)....Ω/Infinite
- 3 Rotor Field Windings....9.7 Ω
- 4 Thermister....Infinite

### C MAIN STATOR WINDINGS

- 1 and 2....0.4 Ω
- 3 Main Stator Aux. Windings....1.3 Ω

### D COMPOUND TRANSFORMER WINDINGS

- 1 and 2....0.4 Ω
- Compound Transformer Aux. Windings 3....4.3 Ω

- E Voltage Regulator (optional)
- F Selector Switch
- G Bridge Rectifier

**Note:** Resistance readings and voltage checks can be accessed easily for the components in the exciter circuit A, G, C-3 and D-3 by locating the color coded wires at the connection points shown on the above schematic. When checking winding resistance values be sure to lift both of the component's electrical connections.

### EXCITER CIRCUIT VOLTAGES (NOMINAL)

Voltages measured across the AC and DC connections on the Bridge Rectifier

AC into Bridge Rectifier: No Load 20 VAC - Full Load 55 VAC

DC out of Bridge Rectifier: No Load 8 VDC - Full Load 18 VDC

# INTERNAL WIRING SCHEMATIC (12 STUD) BT GENERATOR

REFER TO THE TROUBLESHOOTING CHART ON PAGE 3 FOR THE RECOMMENDING COMPONENT TESTING SEQUENCE

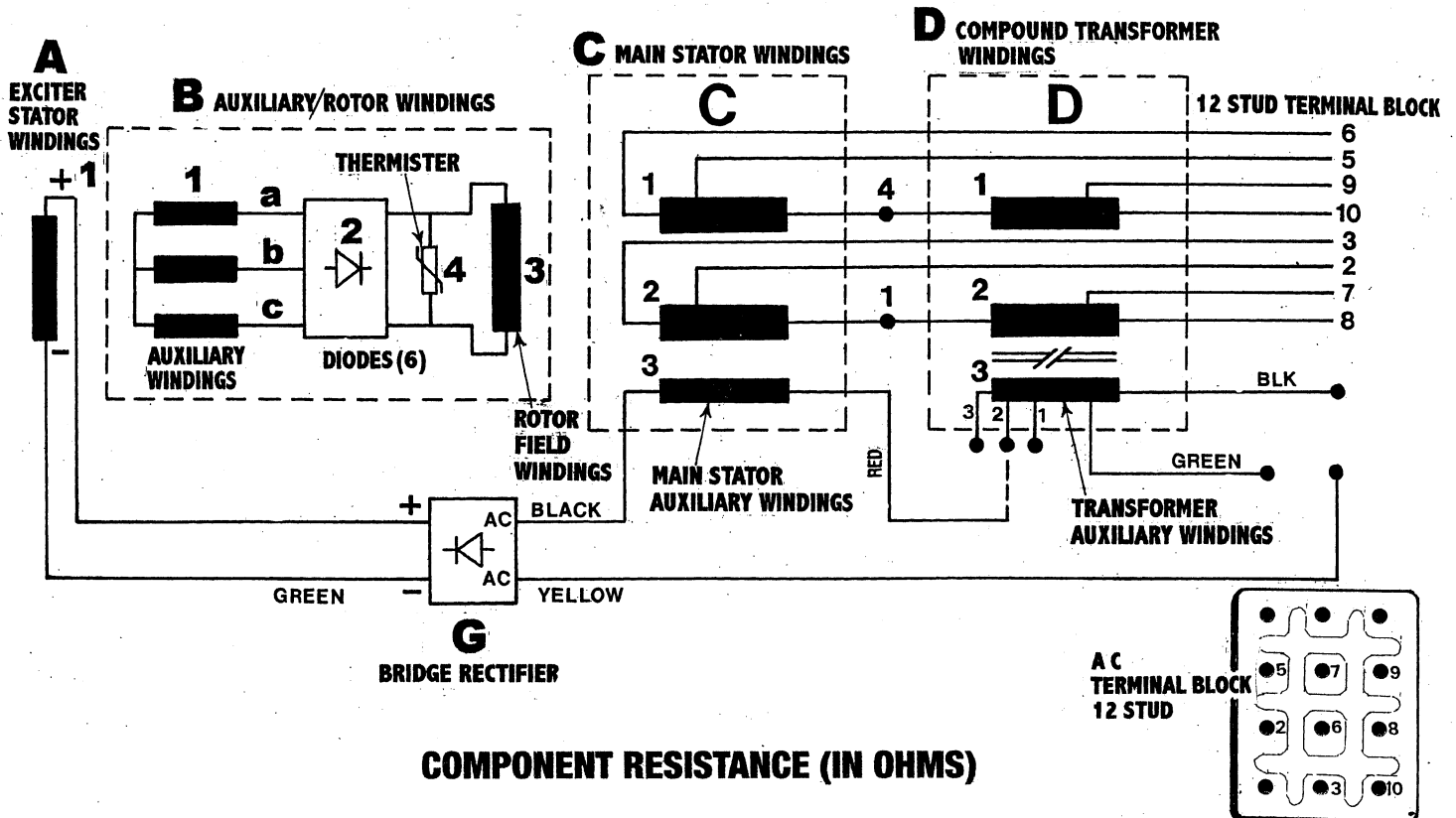

## COMPONENT RESISTANCE (IN OHMS)

### A EXCITER STATOR WINDINGS

1...10.0  $\Omega$

### B AUXILIARY ROTOR WINDINGS

1 a b c Auxiliary Windings are measured in pairs:  
a-b...1.3  $\Omega$ , b-c...1.3  $\Omega$ , c-a...1.3  $\Omega$

2 Diodes (6)... $\Omega$ /infinite

3 Rotating Field Windings...8.1  $\Omega$

4 Thermister...infinite

### C MAIN STATOR WINDINGS

1 and 2...0.6  $\Omega$

3 Main Stator Auxiliary Windings...1.8  $\Omega$

### D COMPOUND TRANSFORMER WINDINGS

1 and 2...0.2  $\Omega$

3 Compound Transformer Aux. Windings...4.3  $\Omega$

### G BRIDGE RECTIFIER

**Note:** Resistance readings and voltage checks can be accessed easily for the components in the exciter circuit A, G, C-3 and D-3 by locating the color coded wires at the connection points shown on the above schematic. When checking winding resistance values be sure to lift both of the component's electrical connections.

## EXCITER CIRCUIT VOLTAGES (NOMINAL)

AC into Bridge Rectifier: No Load 16 VAC - Full Load 45 VAC

DC out of Bridge Rectifier: No Load 7 VDC - Full Load 20 VDC

# MEASURING RESIDUAL VOLTAGE

FOR 6 AND 12 STUD TERMINAL BLOCK GENERATORS

## NO-LOAD VOLTAGE

The amount of no-load voltage produced by the generator can be an indicator of where in the generator the problem/fault may lie.

**Residual Voltage 10-14 Volts [6 Stud]**

**Residual Voltage 18-22 Volts [12 Stud]**

This voltage is the AC voltage produced by the generator from magnetism in the exciter stator field. This voltage is measured between the AC Neutral and Hot leg(s) with no-load on the generator running at 60 hertz.

The presence of residual voltage is an indication that the following generator components are OK.

**Exciter Rotor B-1 a, b, & c and B-2**

**Rotating Field B-3**

**Main Stator C-1 and C-2**

**Compound Transformer D-1 and D-2**

*The fault lies in one or more of the following components in the exciter circuit.*

**Exciter Stator A-1 [and A-2 if applicable]**

**Bridge Rectifier G**

**Selector Switch [if applicable]**

**Main Stator Auxiliary Windings C-3**

**Compound Transformer Auxiliary Winding D-3**

## 12 VOLT EXCITATION

Twelve (12) volt DC excitation applied to the exciter stator windings should cause the generator to produce between 140-150 volts AC measured between the Line and Neutral. (Normal Excitation 8-9 volts DC no load)

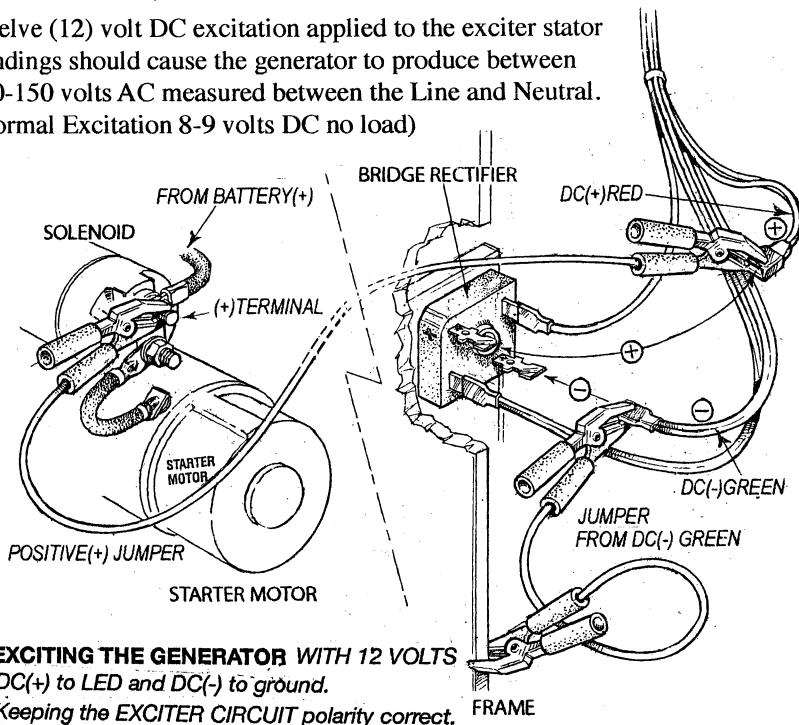

**EXCITING THE GENERATOR WITH 12 VOLTS DC(+)** to LED and DC(-) to ground. Keeping the EXCITER CIRCUIT polarity correct.

Correct voltage produced with 12 volts excitation indicates the fault is in one or more of the above listed components **G, C-3 or D-3**.

If the generator does not produce the correct voltage [140-150V with excitation, then also include the rotor components as possible faults. The Absence of any voltage from the generator indicates a fault with the main stator windings **C-1 and C-2** and/or the compound transformer windings **D-1 and D-2** or possibly a shorted **thermister**.

Apply 12 volt DC excitation to the exciter stator windings as illustrated. A fault in the main stator and/or compound transformer windings such as a short will cause the generator engine to load down and the shorted windings to eventually produce smoke as the excitation is continued.

Voltage output greater than residual and less than rated output 35-100 volts indicates a fault in the exciter rotor/field **B-1, B-2** or **B-3**. Excitation of the generator should produce a partial rise in voltage output and, when removed, the voltage will return to the original low output.

## BRIDGE RECTIFIER WIRING

The illustration below shows the color coded wires at the two AC terminals and the color coded wires at the (+) and (-) DC terminals on both the 6 stud and 12 stud models.

**Note:** When removing or reinstalling connections, maintain correct polarity connection on the (+) and (-) DC terminals.

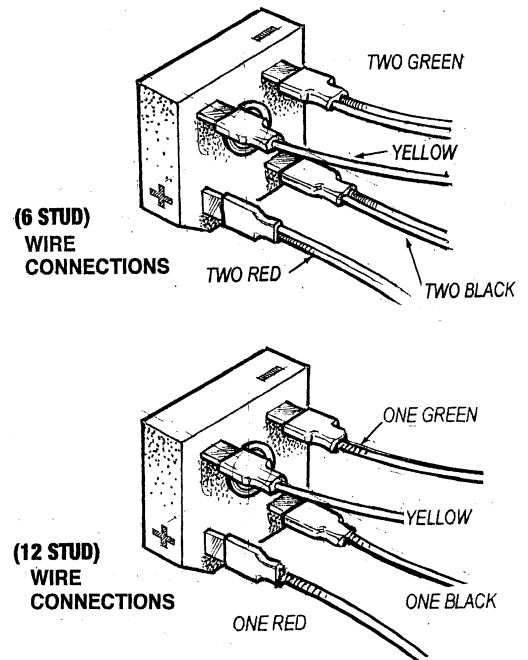

# TESTING EXCITER STATOR WINDINGS

## FOR 6 AND 12 STUD TERMINAL BLOCK GENERATORS

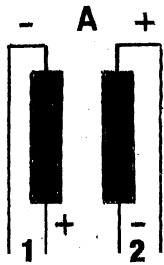

**6 STUD  
STATOR  
WINDINGS**

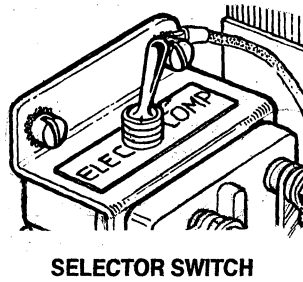

**SELECTOR SWITCH**

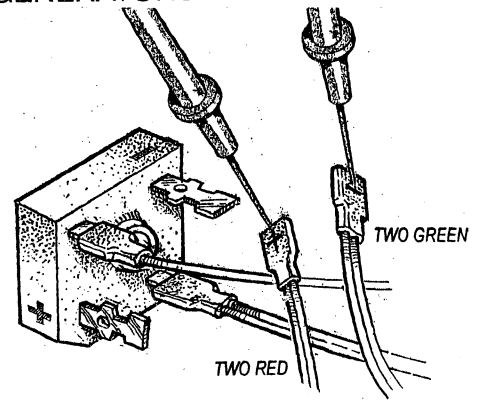

### WINDINGS A-1 AND A-2 TESTING RESISTANCE

Resistance readings for exciter windings **A-1** and **A-2** with the selector switch in the COMP position are taken between the positive (+) and negative (-) leads lifted off the bridge rectifier. Neither of these two leads should have continuity to the generator case/ground. **A-1 & A-2** – 11.5  $\Omega$

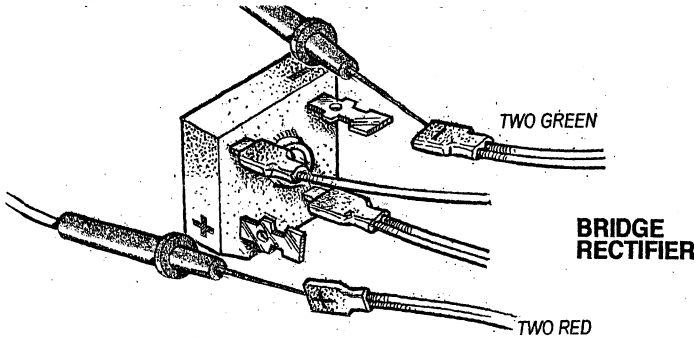

### MEASURING THE EXCITER STATOR WINDINGS – 12 STUD

Readings should be taken between the positive (+) and negative (-) leads lifted off the bridge rectifier. **A**  $\approx$  10.0  $\Omega$

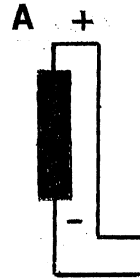

**12 STUD  
EXCITER STATOR  
WINDINGS**

### WINDINGS A-1 TESTING RESISTANCE

Resistance readings for exciter stator windings **A-1** with the selector switch in the ELEC position is taken between the yellow wire and the black wire at the AVR plug. **A-1** – 53.0  $\Omega$

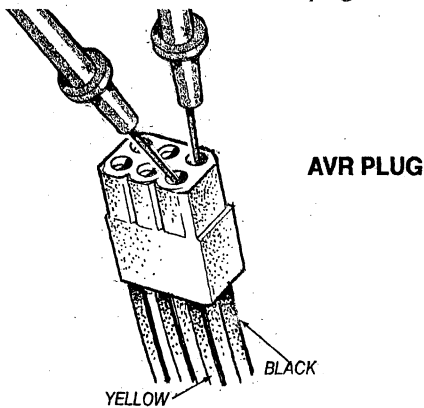

**AVR PLUG**

### WINDINGS A-2 TESTING RESISTANCE

Resistance readings for exciter winding **A-2** with the selector switch in the ELEC position is taken between the green wire lifted off the negative (-) terminal of the bridge rectifier and the red wires lifted off the positive (+) terminal of the bridge rectifier. **A-2** – 13.5  $\Omega$

**Note:** The white striped wiring on earlier model generators has been changed to solid colors on current generators, the colors, however, remain the same.

### TESTING THE BRIDGE RECTIFIER (meter FLUKE multimeter)

1. Set the meter on Ohms scale and connect the positive lead to point #4. Take the negative lead and momentarily touch point #1, #2, #3 and #5. There should be no Ohm value registered on the meter.
2. Remove the positive lead from point #4 and connect the negative lead to it. Momentarily touch points #1, #2 and #3. The Ohm meter should register an arbitrary value at each point it touches.
3. Leave the negative lead on point #4, touch point #5 with the positive lead. The meter should register no Ohm value.
4. Place the positive lead on point #1 and the negative lead on point #3. The meter again should register no Ohm value. Reverse these connections and the meter should register no Ohm value.

If the rectifier fails any of these tests replace the rectifier as it is defective.

**Note:** The AC-DC terminals location may vary on some bridge rectifiers but + and - are clearly marked.

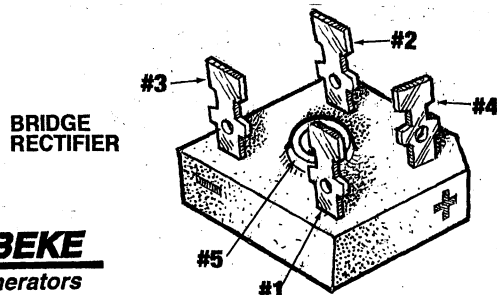

**BRIDGE  
RECTIFIER**



# TESTING EXCITER ROTOR WINDINGS (6 AND 12 STUD)

REFER TO THE WIRING SCHEMATICS TROUBLESHOOTING GUIDES AND COMPONENT RESISTANCE CHARTS IN THIS MANUAL

## B AUXILIARY ROTOR WINDINGS

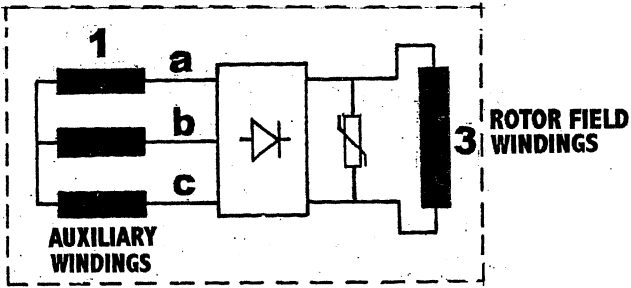

### TESTING AUXILIARY WINDINGS 1 a b and c (6 OR 12 STUD)

Locate the three terminal points on the exciter rotor for these auxiliary winding groups. Position the exciter rotor as shown in the illustration and count off the porcelain knobs from the 12 o'clock point either left or right to locate terminal points **a**, **b** and **c**. Measure the resistance value between the pairs of terminal points **a** & **b**, **b** & **c** and **c** & **a**. There is no need to unsolder these connections unless a faulty reading appears. If this occurs, unsolder and verify the winding fault. There should be no continuity found between any of the three terminal points and the rotor shaft/case ground.

Auxiliary windings 1-a, b and c

6 Stud - 1.5 Ω

12 Stud - 1.3 Ω

### TESTING ROTOR FIELD WINDINGS 3 (6 OR 12 STUD)

Refer to the illustration or diagram of the exciter rotor. The field winding connections are noted as the (+) and (-) connections of the red & white striped wires. Measure the resistance value with your ohmmeter between these two connection points. These connections need not be unsoldered unless a faulty reading appears. If this occurs unsolder the connection and verify the resistance reading. With these connections lifted, there should be no continuity to the rotor shaft. This would indicate a short to ground with these field windings.

Field Windings 3

6 Stud - 9.7 Ω

12 Stud - 8.1 Ω

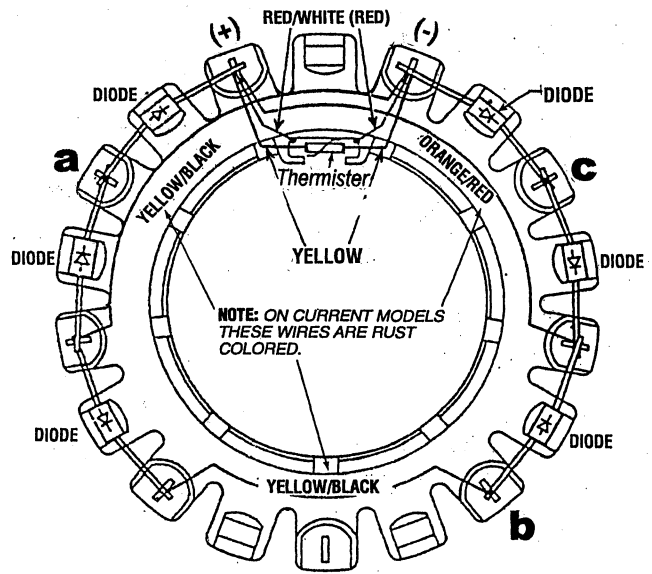
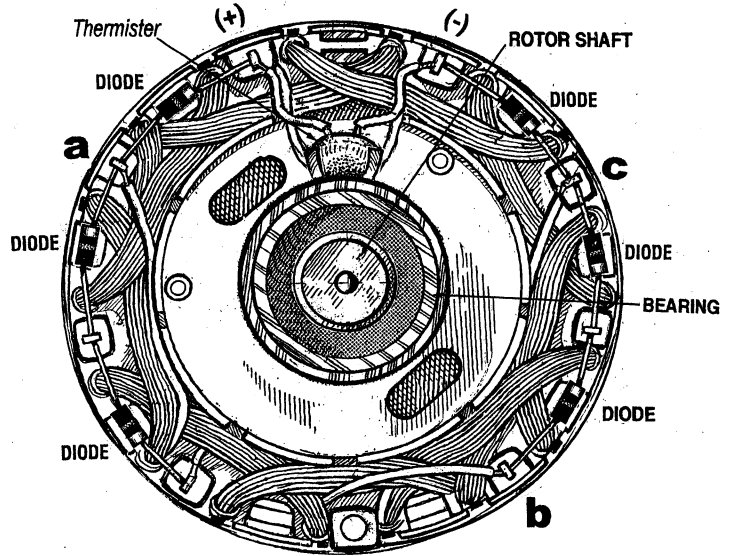
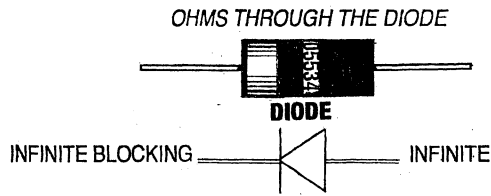

ILLUSTRATION AND DIAGRAM OF THE EXCITER ROTOR

# TESTING DIODES AND THERMISTER (6 AND 12 STUD)

REFER TO THE WIRING SCHEMATICS TROUBLESHOOTING GUIDES AND COMPONENT RESISTANCE CHARTS IN THIS MANUAL



## TESTING DIODES

Six diodes are mounted on the exciter rotor; they rectify the AC voltage produced by the three groups of the auxiliary windings to DC voltages and supply this DC voltage to the rotating field windings.

The diodes can be easily checked in place with the use of a common automotive 12-volt high beam headlight bulb, some jumper leads and the generator's 12 volt starting battery.

A short or an open in a diode can easily be found with the above without having to unsolder and isolate each diode to check it with an ohmmeter.

**Note:** Attempting to check diodes in place with an ohmmeter will give erroneous readings on the diodes due to the auxiliary winding's connections.

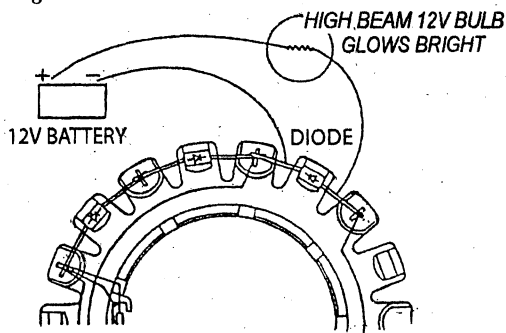

When leads are put across the diode, as illustrated, voltage passes through the diode allowing the headlight to glow brightly.

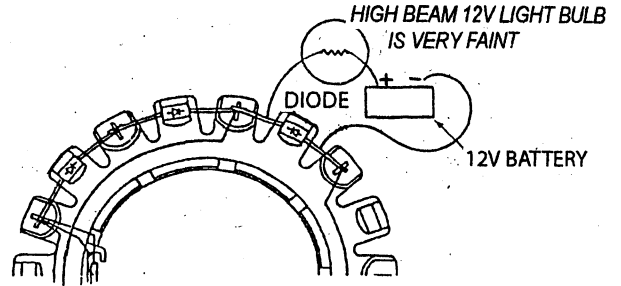

Reverse the leads across the diode. The diode should block voltage passing through it, and the headlight should not glow, or it may glow faintly.

1. Should the bulb not glow with leads connected in both directions, the diode is open internally.
2. Should the bulb glow with leads connected in both directions, the diode is shorted internally.

In both 1. and 2. above, the diode should be replaced. Check the resistance value of the rotating field winding and the integrity of the thermister connected across the + and - connections of the rotating field winding.



## TESTING THE THERMISTER

The thermistor is located on the Exciter Rotor and connects between the + and - connection for the rotating field winding resistance: Infinite.

The Thermister is a voltage absorber when amperage load changes take place with the generator to help prevent/ or reduce light flicker if open circuited, it has no affect on the operation of the generator other than a flicker in the lights when amperage load changes take place not occurring before. Should the thermister short it will negate the affects of the rotating field winding on the stator windings and no AC output voltage will be produced.

When exciting the generator in an effort to locate the cause of a very low or no AC output and the cause is a shorting thermister. There will be no loading of the drive engine. No growling from the AC generator. However as the excitation is allowed to continue the short will produce heat in the thermister and some electrical smell/smoke visible in the area of the rotor rear carrier bearing. The thermister can be removed and the generator operation restored other than for light flicker until a replacement is installed.

# TESTING STATOR WINDINGS (6 AND 12 STUD) VERY LOW VOLTAGE, OR NO VOLTAGE

REFER TO THE WIRING SCHEMATICS TROUBLESHOOTING GUIDES AND COMPONENT, RESISTANCE & CHARTS IN THIS MANUAL

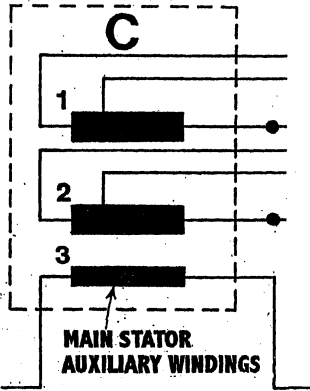

**MAIN STATOR WINDINGS**

**MAIN STATOR AUXILIARY WINDINGS**

## MAIN STATOR WINDINGS C

**Windings Group C-1:** The resistance value is measured between lifted #4 from Junction Terminal or Red Isolation Post below the transformer and lead #6 lifted off the AC terminal Block. To totally isolate this winding group. Also lift lead #5 off the terminal Block

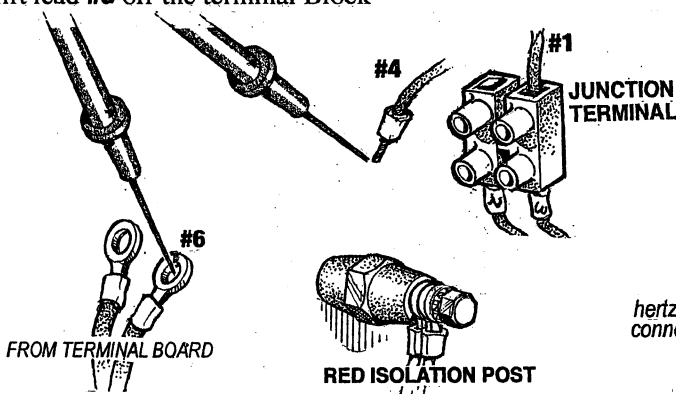

**Windings Group C-2:** The resistance value is measured between the lifted lead #1 from the Junction Terminal or Red Isolation Post below the transformer and lead #3 lifted off the AC Terminal Block. To totally isolate this winding group. Lift lead #2 off the terminal Block.

Main stator windings **C-1** – 0.4Ω **C-2** – 0.4Ω (6 Stud)  
**C-2** – 0.6Ω **C-2** – 0.6Ω (12 Stud)

**Continuity Test:** No continuity should be found between the lifted leads to the case/ground or between the connections of the two groups.

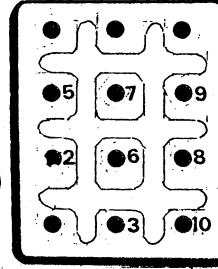
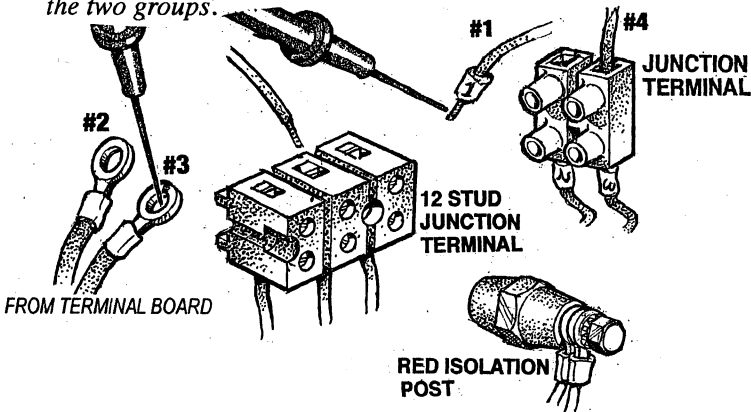

AC TERMINAL BLOCK (12 stud)

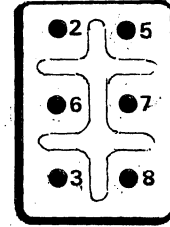

AC TERMINAL BLOCK (6 stud)

## MAIN STATOR AUXILIARY WINDINGS C-3 (6 STUD)

Resistance is measured between the lifted double black AC connection on the bridge rectifier and the lifted double red connection on the Voltage/Hertz Bar.

Main stator auxiliary windings **C-3** 6 Stud – 1.3Ω

**Continuity Test:** No continuity should be found from either of these leads to the case/ground or to either of the transformer groups.

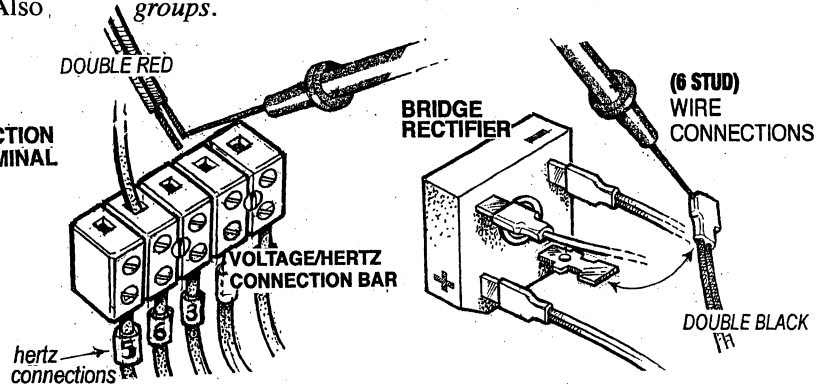

## MAIN STATOR AUXILIARY WINDINGS C-3 (12 STUD)

Resistance is measured between the lifted single black AC connection on the bridge rectifier and the single lifted red lead off the #3 position junction terminal.

Main stator auxiliary windings resistance **C-3** – 1.7Ω

**Continuity Test:** No continuity should be found between the lifted leads to the generator case/ground.

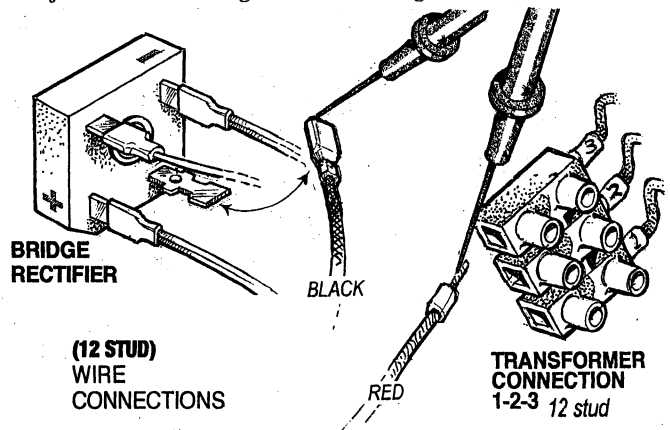

# COMPOUND TRANSFORMER

REFER TO THE WIRING SCHEMATICS TROUBLESHOOTING GUIDES AND COMPONENT, RESISTANCE & CHARTS IN THIS MANUAL

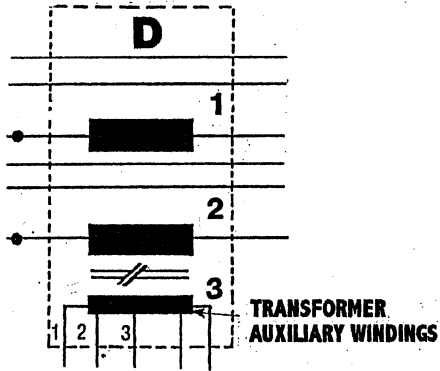

## COMPOUND TRANSFORMER D (6 STUD) MEASURING RESISTANCE

**Windings Group D-1:** Resistance value is measured between lifted lead #4 from the isolation post and lead #8 lifted off the AC terminal block. (illustrated below)

**Windings Group D-2:** Resistance value is measured between lifted lead #1 from the isolation post and lead #7 lifted off the AC terminal block.

Compound Transformer Windings Resistance  
D-1 & D-2 – 0.4Ω

**Continuity Test:** No continuity should be found from either of these leads to the case/ground or to either of the transformer groups.

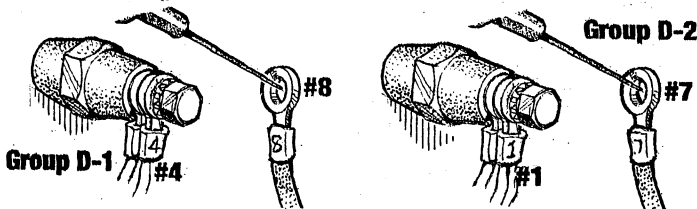

## TRANSFORMER AUXILIARY WINDINGS D-3 (6 STUD)

Resistance value is measured between the yellow wire lifted off the AC terminal of the bridge rectifier (with the selector switch in the ELEC position) and the #1 red lead lifted off the Voltage/Hertz connection bar. Off this same bar, lift the #2 and #3 red leads that come from the auxiliary windings to totally isolate these windings.

Transformer Auxiliary Windings Resistance  
D-3 – 4.3 Ω

**Continuity Test:** No continuity should be found from either of these leads to the case/ground or to either of the transformer groups.

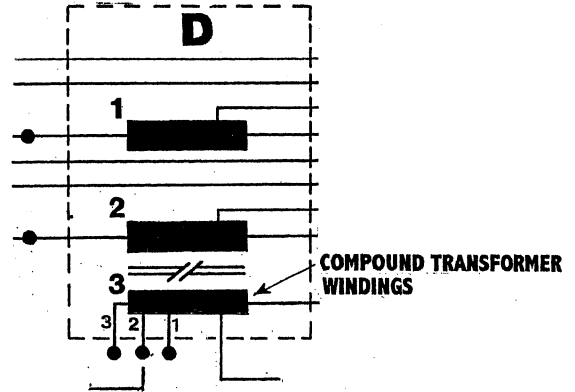
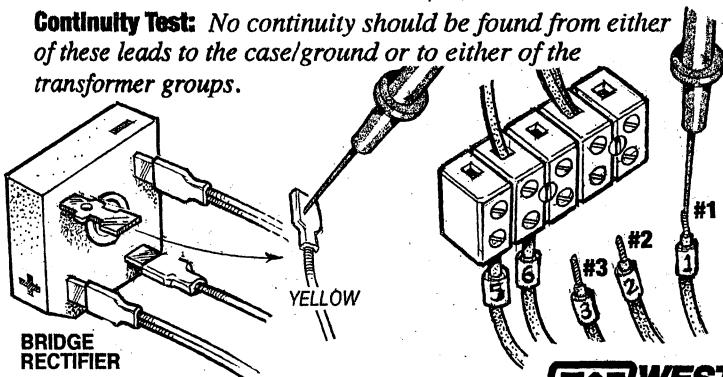

## COMPOUND TRANSFORMER D (12 STUD) MEASURING RESISTANCE

**Winding Group D-1:** Resistance value is measured between lifted #4 lead from the junction terminal and lead #10 lifted off the AC terminal block. To totally isolate the winding lift lead #9 off the AC terminal block.

**Winding Group D-2:** Resistance value is measured between lifter lead #1 from the junction terminal and lead #8 lifted off the AC terminal block. To totally isolate the winding lift #7 off the AC terminal block.

Compound Transformer Windings Resistance  
D-1 & D-2 – 0.2Ω

**Continuity Test:** No continuity should be found from either of these leads to the generator case/ground or between either of the transformer winding groups.

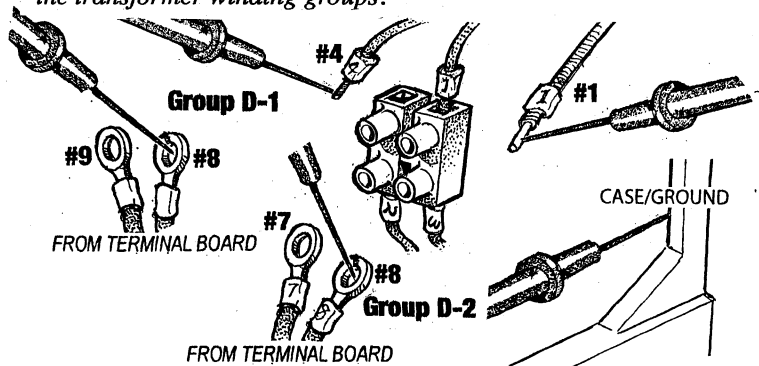

**Transformer Auxiliary-Windings D-3:** Remove all three leads #1, #2, and #3 from the three position terminal strip (located just below the transformer). Lift the black and green leads from the AC terminal block and measure between red #1 and the black lead. Transformer Auxiliary Windings Resistance  
D-3 – 4.3 Ω

**Continuity Test:** There should be no continuity found from any of these leads to the case/ground or to either of the transformer winding group.

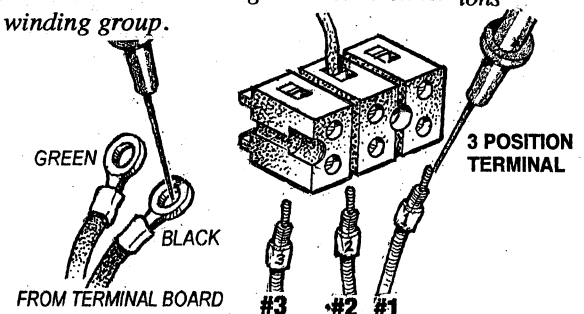

# VOLTAGE ADJUSTMENTS (6 AND 12 STUD)

## NO-LOAD VOLTAGE ADJUSTMENT

Voltage adjustment is made with the generator regulation being governed by the compound transformer.

1. The selector switch [if applicable] must be in the comp position
2. To confirm no-load voltage, start the generator and apply a momentary (moderate) load to excite the transformer. The voltage produced by the generator after the momentary load is removed is no-load voltage. Note the voltage output from the generators 120 volt leg(s) (230 volt 50 hertz). The no-load voltage should be between 121-124 volts at 61.5-62 hertz (232-236 volts at 51.5-52 hertz).
3. To raise or lower the voltage, shims of varying thickness (non-conductive material) are placed or removed from under the steel laminated bar on top of the compound transformer. The material used for shimming should not soften at temperatures in the 176° (80° C) range. A small reduction in no-load voltage (1 to 3 volts) can sometimes be accomplished by gently tapping the top of the laminated steel bar to reduce the gap between the existing shims and the transformer core. Varying the shim thickness by .001 inch (0.025mm) will change the No Load voltage by 4-6 volts.

## FULL-LOAD VOLTAGE ADJUSTMENT

Voltage/Hertz connection bar (6 stud) and the three position terminal (12 stud)

The three red connections coming into these two components can be used to increase AC voltage to the bridge rectifier or lower it by moving the single/double red connection on the other side from #3 to #2 or #1 to increase and from #1 to #2 or #3 to decrease. Increasing AC voltage to the rectifier will increase excitation and the AC output. Decreasing AC voltage to the rectifier will lower excitation and the AC output. These

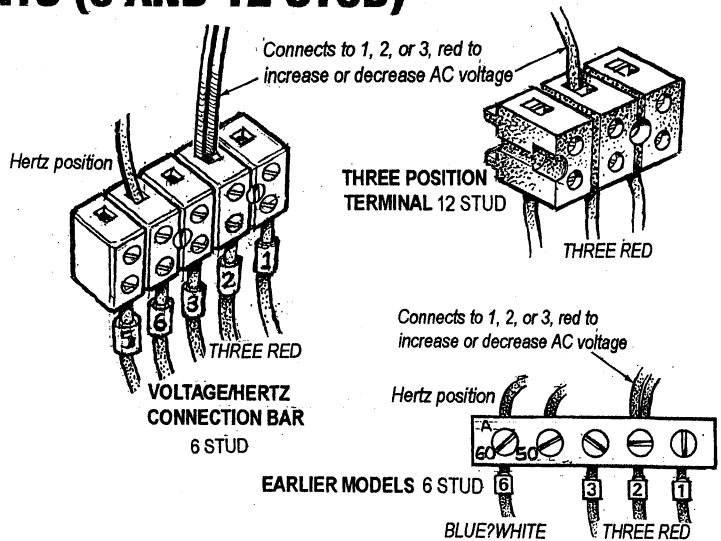

connections are generally used to increase excitation when at full amperage load the AC output of the generator falls below acceptable levels 108 volts – 60 hertz or 210 volts – 50 hertz. Note: Hertz/Speed drop is not the issue. No-load voltage may need to be adjusted when these connections are moved.

**Note:** Do not use these adjustments to compensate for overload conditions being placed on the generator/engine (inductive-motor type loads). Loss of generator hertz/speed, the result of this type of overload, will cause a drop in voltage output.

## CHANGING FREQUENCY/HERTZ

When changing generator Frequency/Hertz in the field refer to the models Operator Manual or Service Manual for the proper procedures. These procedures will vary greatly depending on the many different generator models both gasoline and diesel the BT six stud and 12 stud generators are used on. AC Terminal Block configurations and winding group illustrations for the 6 and 12 stud BT generators are shown on the next page.

# AVR SELECTOR SWITCH AND PLUG CONNECTIONS (6 STUD)

## SELECTOR SWITCH AND CONNECTIONS

This switch is normally set in the COMP position. If an optional AVR is installed, the switch is toggled to the ELEC position.

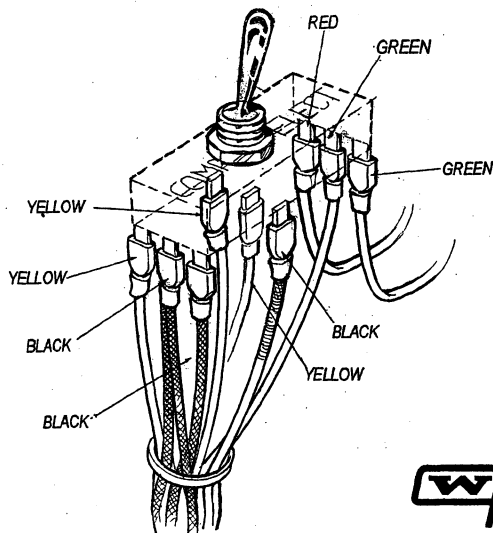

**Note:** With the selector switch in ELEC position the exciter stator windings are divided, one group is excited through the bridge rectifier and the other group through the A.V.R.

## A.V.R. PLUG AND CONNECTIONS

**Note:** Striped wires were used on early model generators. The colors will, however, match up to the current solid color wires.

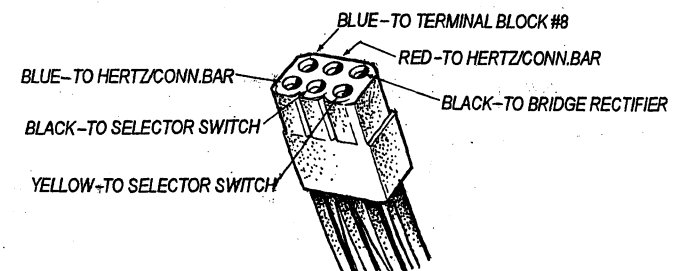

# AC TERMINAL BLOCK CONNECTIONS AND WINDING DIAGRAMS

FOR 6 AND 12 STUD TERMINAL BLOCK GENERATORS

## AC TERMINAL BLOCK CONNECTIONS (6 STUD)

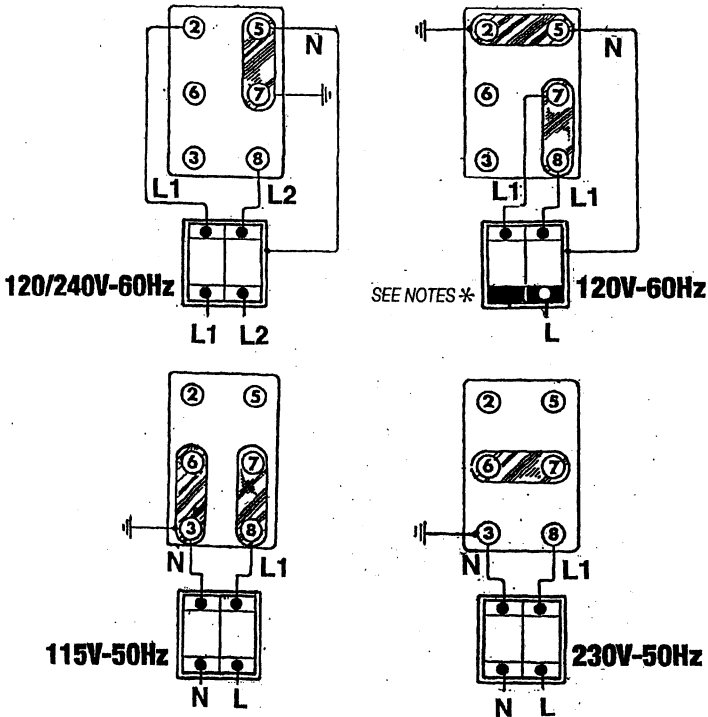

## WINDING DIAGRAM (6 STUD)

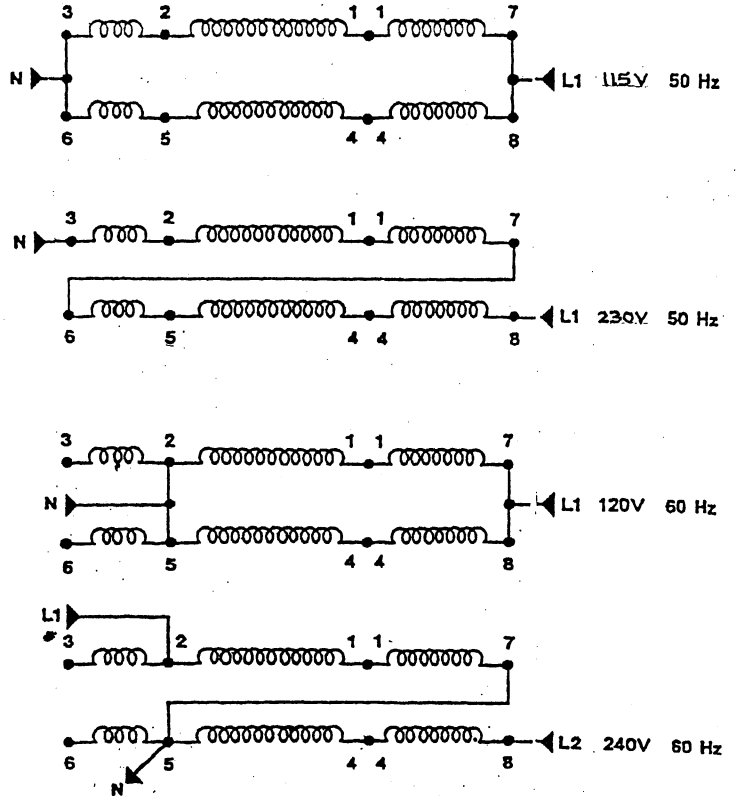

## AC TERMINAL BLOCK CONNECTIONS (12 STUD)

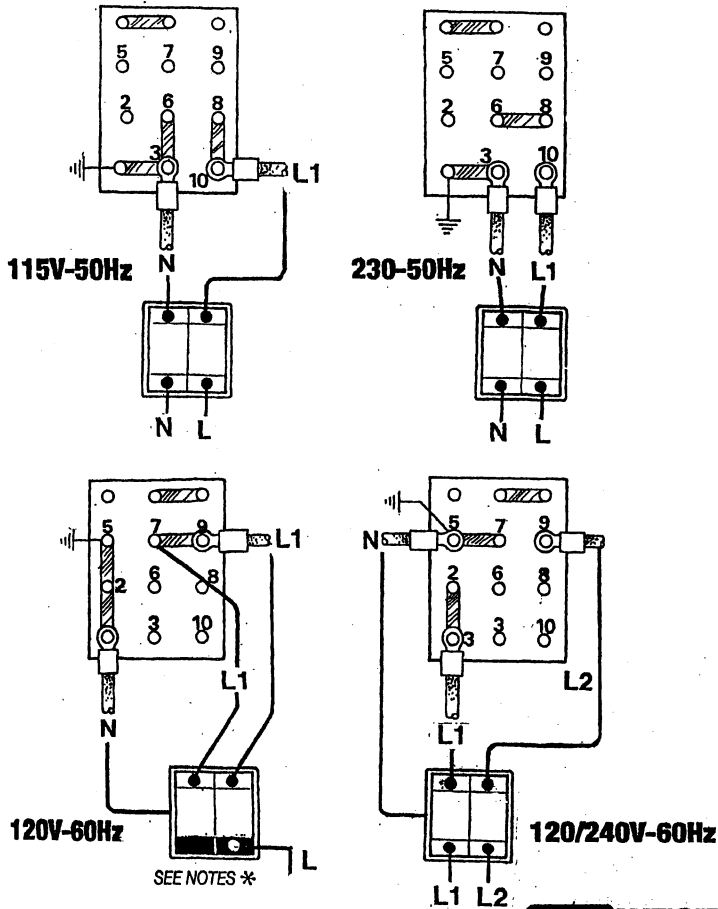

## NOTES

The winding diagrams show the connections necessary to obtain the correct voltage and frequency.

The Ground Wire that connects from the Neutral Stud to the Generator Frame must be moved when changing from 115V-50Hz to 230V-50Hz.

For Output Leads from the AC Terminal Block use terminal ends for 1/4" studs that accept multi-strand copper wire sized for the rating from the hot lead connection.

\* When wiring 120/60hz, a jumper is required between the lead connections.

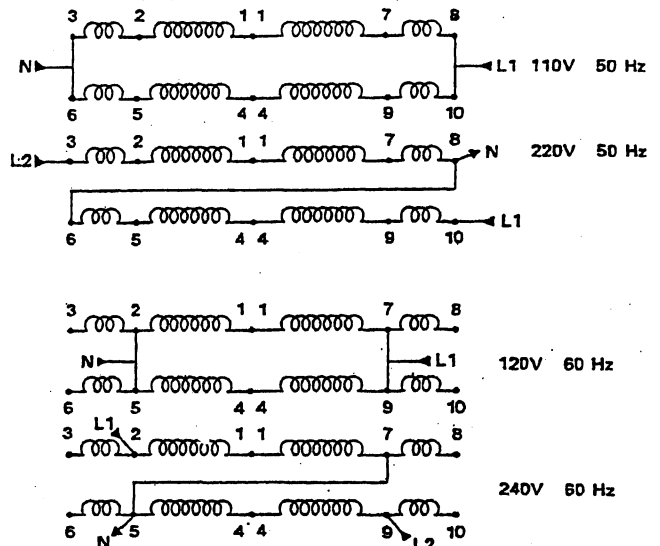

## WINDING DIAGRAM (12 STUD)



